

# SWAROVSKI

APPLICATION MANUAL 2016



# CONTENTS

---

## 09 GENERAL INFORMATION

- 10 Application Manual
- 10 Application Online
- 11 Application Services
- 14 General Product Information
- 21 Swarovski Products and Suitable Application Techniques

---

## 23 SOLDERING, PLATING, AND STONE SETTING

- 24 Product Overview
- 24 Machines, Tools, and Aids
- 25 Suppliers
- 26 Application
- 34 Directions for Jewelry Manufacturing
- 36 Quick Assistance

---

## 39 GLUING

- 40 Product Overview
- 40 Machines, Tools, and Aids
- 43 Suppliers
- 45 Application
- 58 Overview of the Application Processes
- 59 Product-specific Application Instructions
- 64 Useful Information
- 67 Quick Assistance

---

## 71 CERALUN

- 72 Product Overview
- 73 Machines, Tools, and Aids
- 75 Suppliers
- 76 Application
- 81 Useful Information
- 82 Quick Assistance

---

## 85 HOTFIX APPLICATION

- 86 Product Overview
- 86 Machines, Tools, and Aids
- 88 Suppliers
- 89 Application
- 97 Useful Information
- 100 Quick Assistance
- 101 Swarovski Hotfix Selector

---

## 111 SEWING, EMBROIDERY, AND HAND APPLICATION

- 112 Product Overview
- 112 Machines, Tools, and Aids
- 115 Suppliers
- 116 Application
- 123 Useful Information
- 124 Quick Assistance

---

## 127 MECHANICAL APPLICATION

- 128 Product Overview
- 128 Machines, Tools, and Aids
- 143 Suppliers
- 151 Application
- 160 Useful Information
- 161 Quick Assistance

---

## 163 CARE INSTRUCTIONS

- 164 Textile Care Instructions
- 167 General Care Instructions
- 168 Laws, Regulations, Norms, and Standards
- 168 Warning Notices
- 169 Care Instructions

Swarovski is the premium brand for the finest crystal embellishments since 1895. It is recognized for its innovative excellence and its collaborations with top-class designers and brands in the fashion, jewelry, accessories, interior design, and lighting industries across the globe.

Available in myriad colors, effects, shapes, and sizes, crystals from Swarovski offer designers a fabulous palette of inspiration, and are produced according to the innovative, lead-free\* Advanced Crystal standard. Born out of a passion for detail and high-precision cutting, these precious ingredients impart refined glamour to everything they embellish. They can be recognized by the 'Crystals from Swarovski' seal, which serves as a certificate of authenticity that identifies products made with genuine Swarovski crystals.

A family-owned company for more than 100 years, with values rooted in integrity, respect, and excellence, Swarovski is noted as much for its ethics in business as for its contemporary artistry and innovative flair.

[SWAROVSKI.COM/PROFESSIONAL](https://www.swarovski.com/professional)

\* Crystal glass and all other materials containing 0.009% lead or less.



## SEAL YOUR SUCCESS

Be part of our exclusive Ingredient Branding program



SWAROVSKI

CRYSTAL COLLECTION

TAKE THOUSANDS OF CRYSTALS WHEREVER YOU GO

## INSPIRATION IS ONLY AN APP AWAY

Wherever you are, whatever you're looking for, search over 15,000 loose elements and 200,000 forward-integrated elements with Swarovski's inspirational new Crystal Collection App. Online or offline, stay app-to-date with the latest innovations and find popular classics – it's easy to install, easy to browse, easy to use.



Made for iPad



Made for Tablets

[SWAROVSKI.COM/COLLECTIONAPP](http://SWAROVSKI.COM/COLLECTIONAPP)

## EXCELLENCE, THROUGH INNOVATION AND ORIGIN

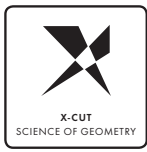

**X-CUT**  
Advanced optical measurement and high-precision manufacturing deliver premium cuts characterized by unmatched brilliance.



**HOTFIX GLUE**  
The variable temperatures at which Hotfix glue can be activated enable the application of crystals on a broad range of textiles.



**PLATINUM PRO**  
With its new advanced foiling technique, Swarovski has set a new standard in the lifespan of crystals.



**CRYSTALS - MADE IN AUSTRIA**  
The combination of innovation with sustainability and respect for individual wellbeing means that quality is always assured.

## PREMIUM, BY SERVICE AND DESIGN



**DESIGN SERVICE**  
Throughout its global network of Design Centers, Swarovski offers exceptional service provided by the industry's best creative talent.



**GLOBAL SERVICE**  
Swarovski's Global Service Network provides customers with dedicated personal assistance on a local level.



**APPLICATION SERVICE**  
A comprehensive range of application services means customers benefit from the extensive experience of leading international experts, as well as internal specialists.



**DESIGNER EDITIONS**  
Creative collaborations with top designers result in exclusive cuts and unique designs for Swarovski crystal.

## COMPLIANCE, WITH INTEGRITY



**ADVANCED CRYSTAL**  
Swarovski's patented lead-free\* formula has changed the DNA of crystal while still offering the same sparkle, dependability, and variety for which Swarovski is famous.



**CLEAR**  
Regular legal monitoring of chemical requirements and reasonable testing provide customers with the comfort of trust in Swarovski's products.

\*Crystal glass and all other materials containing 0.009% lead or less.



**OEKO-TEX**  
Oeko-Tex® Standard 100 Class II (direct contact with skin) certification creates confidence in chemical safety of textile applications.



**COMPLIANCE SERVICE**  
Assessments regarding substance limitations as well as compliance information and advice to support customers in complying with relevant laws, regulations, and voluntary standards.





[SWAROVSKI.COM/PROFESSIONAL](https://www.swarovski.com/professional)

## **GENERAL INFORMATION**

Swarovski offers a comprehensive range of services, tailored to customers' requirements, for the application of Swarovski products.

## APPLICATION MANUAL

This Application Manual offers extensive information on the various Application Services provided by Swarovski. Thanks to their outstanding quality, and with the help of specially developed application techniques, Swarovski products can be processed easily and quickly to produce a high-quality finished product. The processes involved are described in this manual on a step-by-step basis, with photos and illustrations.

Each application method contains detailed information on the following areas:

Product Overview	Swarovski products that are suitable for the application technique in question
Machines, Tools, and Aids	List of machines, tools, and aids necessary for application
Suppliers	Selection of suppliers that sell these machines, tools, and aids
Application	Detailed description of the entire application process and the product-specific procedure. Furthermore, the Hotfix Selector outlines extensive application parameters for suitable product and carrier material combinations
Useful Information	Advice and tips on working with Swarovski products
Quick Assistance	A checklist of typical application problems, along with possible causes and recommendations on avoiding them (in each chapter these are marked with a <b>?!)</b>

Extensive care instructions and further information on laws, regulations, norms, and standards are featured at the end of the manual.

## APPLICATION ONLINE: SWAROVSKI.COM/PROFESSIONAL

All the information contained in this manual is regularly updated on the Swarovski products business website (SWAROVSKI.COM/PROFESSIONAL). In addition, application techniques are demonstrated through animations and videos. The site is an excellent way to find out about Swarovski's application services and application techniques.

To gain access to the restricted section of the business website, please contact your local Swarovski representative.

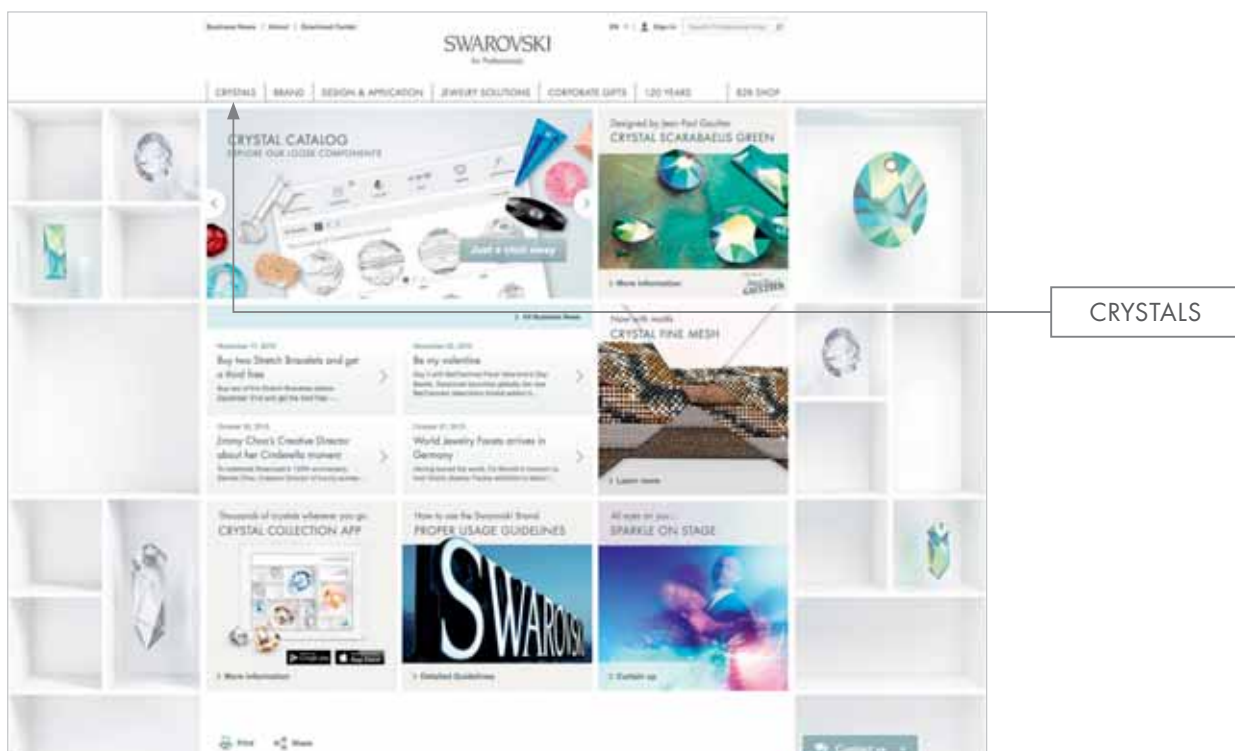

## APPLICATION SERVICES

Swarovski offers a comprehensive range of services, tailored to your requirements, for applying Swarovski products. In doing so, the company aims to meet the needs of each industry, and to jointly offer flexible and integrated solutions.

- Technical enquiry service
- Compliance service
- Technical customer support – field services
- Application partner network

### Technical enquiry service

Available worldwide, the technical enquiry service can help you in the following areas:

- Product information
- Technical drawing
- Care instructions
- Information on industry standards
- Individual application tests based on customer samples
- Information on machines, tools, and aids

### Compliance service

The worldwide available compliance service can support you in the following areas:

- Certificates
- Information on laws and regulations
- Compliance information of Swarovski crystals
- Compliance statement to customer-specific requirements

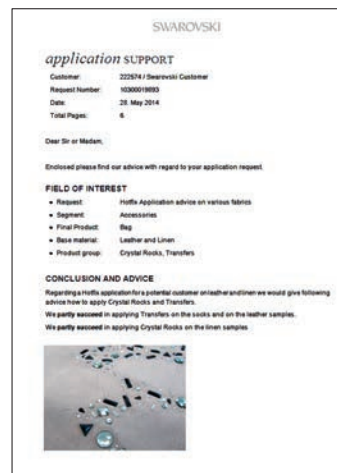
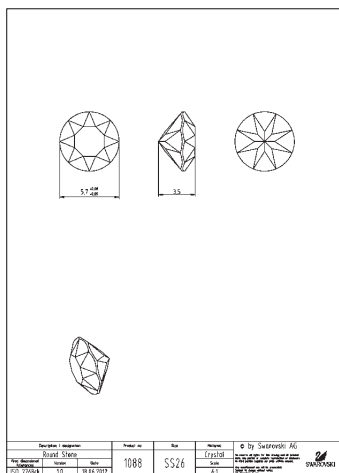

For further information, please contact your local Swarovski office.

### Technical customer support – field services

Swarovski imparts its crystal application expertise through customized **Crystal Application Workshops, Crystal Application Consultancy, Troubleshooting, and Technical Assessments**. These can take place either on customers' premises or at Swarovski locations. The focus is always on customers' individual needs, the efficient use of Swarovski products, and on the quality of the crystal application.

Our services have been created to take advantage of our comprehensive crystal application expertise in the following areas: mastery of the relevant techniques, technical knowledge of Swarovski products, process-engineering competencies, and our experience of crystal application equipment, together with our product manufacturing knowledge of various industries.



**Service results** (dependent on the particular individual service package):

PREVENTION OF INCREASED DEVELOPMENT COSTS THROUGH TECHNICAL INPUT IN:

- The correct choice of Swarovski products
- The correct technical design
- The correct application technique
- The correct integration of an application process into the entire process landscape
- Application process set-up

PREVENTION OF COST COMPLAINTS THROUGH TECHNICAL INPUT IN:

- The correct positioning and arrangement of Swarovski products
- Learning how to check the quality of crystal applications
- Suitability of the customer's equipment, tools, and aids

PREVENTION OF INCREASED STAFF DEVELOPMENT COSTS THROUGH:

- Staff training in appropriate application techniques
- Building your technical knowledge base, thereby enabling you to be self-sufficient

## Application partner network

As a company with a global sales network and deep understanding of the market, Swarovski has comprehensive knowledge of various application companies and their services from around the world.

Based on this knowledge, Swarovski has developed a global application partner network. These partners offer a wide range of technical and product-related services, as well as tailored production solutions. In order to qualify and to get access to the application partner network, certain criteria with regard to application techniques, know-how as well as product assortment need to be fulfilled by the application partners.

Application partners can assist you with a variety of application techniques, such as gluing, Hotfix application, sewing, embroidery, and mechanical application. In addition, many partners can carry out technically complex solutions, such as Flat Back Leather and the automated, mechanical application of Rivets. The services offered by our partners range from product and design consultancy, to prototyping and carrying out production, and make up a key component of our customer focus.

Should you require a professional partner to assist you in applying items such as Flat Backs onto interior, Transfer Motifs onto T-shirts, Rivets onto belts, or Plastic Trimmings onto jeans, the "Application Partner Platform" or your local Swarovski office can offer guidance.

## Application Partner Platform (APP)

The Application Partner Platform enables you to find the right application partner swiftly and easily, wherever in the world production may be taking place. Through a tailored "search function", you can send out a specific, detailed request (e.g. searching for a specific country, an application technique, or products) to select partners around the world.

The platform is made up of two core areas – "Find a Partner" and "Become a Partner":

### Find a Partner

Using the search function, this area enables you to locate the best application partner for your application work. You are immediately provided with a list of application partners, which you can download and save. If you use the search function for a specific enquiry regarding an application service, you receive detailed information from the application partners contacted.

### Become a Partner

If you are interested in becoming an application partner yourself, the "Become a Partner" section contains key information on the requirements and an application form to complete. Your local Swarovski office will then contact you as soon as possible.

The screenshot shows the 'Find a Partner' search form on the Swarovski Professional website. The form is titled 'Find a Partner' and includes a search bar with the text 'Please fill out the search fields to find the right partner for your request.' Below the search bar, there are several input fields: 'Company', 'City', 'Continent' (with a dropdown menu showing 'please choose'), and 'Country' (with a dropdown menu showing 'please choose'). At the bottom, there are checkboxes for 'Products', including 'Flat Backs Hotfix', 'Flat Backs for Hotfix', 'Crystal Tattoos', and 'Crystal Trimmings'.

Access to the Application Partner Platform:

Part of the "Application Partner Platform" is located in the restricted area of the business website [SWAROVSKI.COM/PROFESSIONAL](https://www.swarovski.com/professional). Under "Design & Application" → "Application & Manufacturing" you will find access to the Application Partner Platform.

For access to the restricted area of the business website and for further information, please contact your local Swarovski office or register online on the business website.

## GENERAL PRODUCT INFORMATION

This list offers an overview of Swarovski products that are suitable for the application methods described. Product categories/ descriptions are based on the 2014 Collection.

<b>Round Stones</b>	Round Stones are loose crystal elements. Most of them are pointed on the reverse side, making them easy to apply in either metal claw settings or pre-set cavities in die-cast metal alloys. The assortment features a wide variety of different cuts, the most innovative one is the XIRIUS Chaton.
<b>Fancy Stones &amp; Settings</b>	Fancy Stones are offered in numerous shapes ranging from classical gemstone-inspired cuts to progressive trend cuts. They come in a huge assortment of different sizes and colors. Showing either a faceted or flat reverse side, Fancy Stones can be glued into pre-cast cavities or used in metal settings. Their precision-cut facets ensure the highest brilliance and endow design ideas with a unique sparkle.
<b>Beads</b>	Beads offer the highest standard available on the market. The high-quality precision cutting and the clear through-hole achieve high brilliance and clarity. Rounded hole edges reduce the wear on thread and increase the durability of designs. The assortment is divided into classic, romantic, and progressive shape characteristics. They are available in the latest fashion colors, effects, and cuts.
<b>BeCharmed &amp; Pavé</b>	The BeCharmed assortment, from Beads, Crystal Pearls, Pavé, and Rondelles, to Stoppers and Pavé Balls in a brilliant array of colors and effects, offers unlimited combination possibilities. All products of this unique line feature a high-quality stainless steel part with Swarovski branding and a 4.5 mm-diameter hole, which is the standard size for existing charm concepts, making BeCharmed pieces ideal collectibles.
<b>Crystal Pearls</b>	Crystal Pearls are perfect replicas of genuine pearls. They are made of a unique crystal core covered with an innovative pearl coating, which features a flawless, silky smooth, rounded surface. They are available in a variety of shapes, sizes, and colors and are delivered loosely threaded or, if desired, also knotted.
<b>Pendants</b>	Pendants have timeless elegance and are available in a large range of classical and avant-garde cuts and shapes, as well as in many colors and effects. Pendants offer a whole range of design possibilities for different segments thanks to their easy application, with the hole on top requiring only a jump ring/ pinch bail with a chain or cord.
<b>Flat Backs No Hotfix</b>	Flat Backs No Hotfix are loose crystal elements backed with platinum foiling for extra brilliance and protection. These Flat Backs are easy to apply to a variety of carrier materials using standard one- or two-component glues. They are available in a multitude of sizes, colors, shapes, and cuts.
<b>Flat Backs Hotfix</b>	Flat Backs Hotfix are loose crystal elements with a flat reverse side that has been pre-coated with a heat-sensitive glue. These Flat Backs can be easily applied to a large range of textile carrier materials using heat to produce a durable and long-lasting crystal effect. Flat Backs Hotfix are available in a multitude of colors, shapes, and cuts.
<b>Sew-on Articles</b>	Sew-on Articles are loose crystals that can be easily sewn (either by hand, or with a standard domestic or industrial embroidery sewing machine) onto any type of textile or accessory. Sew-on Articles come in two- or three-hole varieties, including round, oval, and triangle holes for use in a wide range of decorative applications for fine embroidery or even jewelry. Lochrosen are crystals with just one hole. Sew-on Articles have rounded edges on the hole entry and exit areas to guarantee thread protection.
<b>Self-adhesive Elements</b>	Self-adhesive Elements such as Crystal-it, Crystal Fabric-it, Crystaltex-it Chaton or Crystal Rocks-it are eye-catching and innovative products that come ready-to-apply. They are pressure-sensitive and self-adhesive. When applied to paper and solid surfaces, they can create elegant, romantic, or sporty designs.
<b>Transfers</b>	Transfers are ideal for Hotfix application on all kinds of textiles. They are available in a large range of motifs and numbers of rows, which are made up of different articles from the Flat Back Hotfix assortment. Featuring designs from the in-house design team, they can comprise XIRIUS and XILION Roses, or Creation Stones, as well as Metallics and Cabochons.
<b>Synthetics Hotfix</b>	These versatile products open up a multitude of creative design possibilities through their numerous application techniques. They combine elegant crystals from Swarovski that can be applied using Hotfix technology with synthetic carrier materials. They are ideal for use in the textile, interior design, jewelry, and accessories segments.
<b>Plastic Trimmings</b>	Plastic Trimmings are plastic carrier materials with integrated crystals. These multi-functional products can either be hand- or machine-sewn or glued onto various surfaces. The range of bandings not only offers a color selection of chatons, but also a variety of casing colors.
<b>Buttons, Fasteners &amp; Zippers</b>	Crystal Buttons can be used in exactly the same way as standard buttons. The assortment of available buttons ranges from those for shirts, blouses, jackets, and coats, to buttons for denim and accessories. They are suitable for hand and mechanical application. Zippers from our assortment are unique because the crystals are integrated into the zipper teeth, allowing them to be used in the same way as standard zippers.

<b>Metal Trimmings</b>	Metal Trimmings are forward-integrated metal products. They can be sewn by hand or machine and mechanically applied onto different fabrics or other materials. Metal Trimmings are bestsellers among the textile, shoe, and accessories segments because their wide range of application possibilities ensures that they can be used in a multitude of different ways.
<b>Crystal Mesh</b>	Crystal Mesh is a flexible metal mesh carrier with integrated loose crystals. The product is available in a wide range of colors and casings, either as a Hotfix version, which can be applied using heat, or as a No Hotfix version that can be hand- or machine-sewn.
<b>Cupchains &amp; Findings</b>	These products are metal chains and findings that can integrate either Round or Fancy Stones and Beads into any creative design. They can be divided into seven sub-categories: Single Stone Settings, Cupchains and Brass Components, Multi Stone Settings, Channels, Metal Buttons, Rondelles, and Linked Findings. Each of these groupings is available in a wide variety of shapes, sizes, colors, and platings.

### Crystal specifications

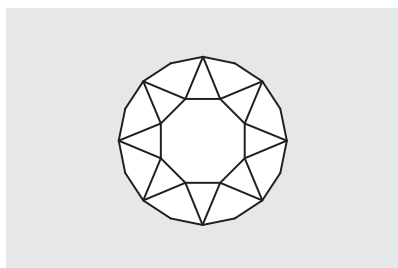

Front view

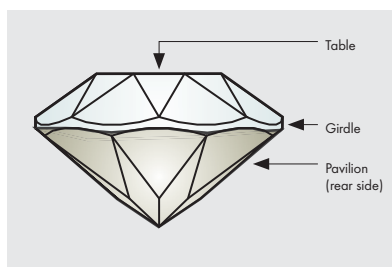

Side view

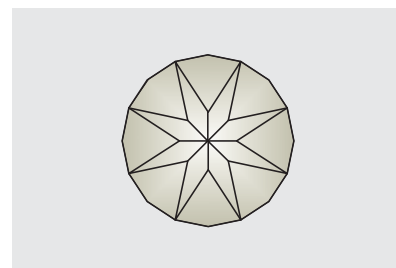

Rear view (Pavilion)

### Foiling

Foiling is the process of mirror coating the reverse side of the crystals.



#### Silver Foiling (A)

A silver mirror finish for XIRIUS and XILION Hotfix articles only.



#### Platinum Pro Foiling (F)

A silver mirror finish that is coated with a platinum colored protective layer of highest quality. The Platinum Pro Foiling is not only resistant to environmental damage from chlorine, salt water, and perfume – it can also withstand processes such as soldering and electroplating, giving it unprecedented durability (e.g. art. 4120).



#### Aluminum Foiling (M)

An aluminum mirror finish is applied using a vacuum coating process (e.g. art. 2855 Flat Back HF).



#### Protective Layer (P) for Beads and Pendants

Protective layer is a transparent lacquer system that is applied over the effects. This lacquer is designed to protect the effects from scratches, fingerprints, and other damage and also helps to prevent moisture that can lead to corrosion (e.g. from perspiration) penetrating into the effect layer when jewelry is designed to incorporate Crystal Stones that are not set in casings/settings.



#### Unfoiled (U)

## Effects

### Vacuum Coating Effects

Vacuum coating processes on the surface of the crystal produce either a special surface or a translucent effect, according to the application methods used.

Please find below a list of all Swarovski effects followed by an explanation of the special vacuum coating processes.

### Surface Effects

(Vacuum coating on the surface of the crystal)

	Effect Code	Name
	AB	Aurore Boreale
	ANTP	Antique Pink
	API	Astral Pink
	BLSH	Blue Shade
	BRSH	Bronze Shade
	CAL	Comet Argent Light
	COP	Copper
	DOR	Dorado
	GSHA	Golden Shadow
	HEM	Hematite (only on Jet)
	IRIG	Iridescent Green
	LISH	Lilac Shadow
	LTCH	Light Chrome
	LUMG	Luminous Green
	METSH	Metallic Sunshine
	METBL	Metallic Blue
	MLGLD	Metallic Light Gold
	MOL	Moonlight
	NUT	Nut (only on Jet)
	PARSH	Paradise Shine
	REDM	Red Magma
	ROGL	Rose Gold
	SAT	Satin
	SCGR	Scarabaeus Green designed by JPG
	SSHA	Silver Shade
	TRA	Transmission

### Translucent Effects

(Vacuum coating on the reverse side of the crystal, effect shines through the transparent crystal)

	Effect Code	Name
	BBL	Bermuda Blue
	HEL	Heliotrope
	MBL	Meridian Blue
	SINI	Silver Night
	TAB	Tabac
	VL	Vitrail Light
	VM	Vitrail Medium
	VOL	Volcano

### Patina Effects

(Partial coating of the correspondingly modified effects)

Effect Code	Name
BLAPA	Black Patina
GOLPA	Gold Patina
ROSPA	Rose Patina
SILPA	Silver Patina
WHIPA	White Patina

### Lacquer<sup>PRO</sup> Effects

A premium opaque varnish which is applied to the reverse side of the crystal instead of foiling, resulting in an opalescent appearance.

Effect Code	Name
L104	Powder Blue
L102	Powder Green
L105	Powder Grey
L103	Powder Rose
L101	Powder Yellow

### Variations on Surface Effects

#### 2x



Both sides of the stone are treated with an effect (e.g. art. 5000AB 2).

#### B



Effects on three sides of a cube shape (e.g. art. 5601 AB B).

#### V



The effect is used in reverse. A surface effect is used like a translucent effect (e.g. art. 2420 NoHF SSHA V - Silver Shade on the reverse side).

#### Z



Only a part of the stone is treated with an effect (e.g. art. 4869 HEL Z).

### FC (Full Coated)

Improved technology allows for the perfectly homogeneous, all-round application of high-intensity metallic effects in the Bead assortment (art. 5000).

### CAL'V'SI & CAL'VZ'SI

The effect CAL (Comet Argent Light) is also used as a mirror coating on the reverse side of the crystal instead of standard foilings (A, F, ...) in special cases (e.g. art. 2035).

### /G

Article with partly (PF) or fully frosted (FF) surface (e.g. art. 2611/G)

### PA (Patina)

Innovative technology allows for the partly coated application of adapted effects. Its historical edge and "used" look give it a certain timelessness, without losing its crystalline appearance (e.g. art. 2034).



### Special Surface Effects

Swarovski has been able to achieve various special surface effects by using special chemical and mechanical processes on the surface of the crystals.



MAT



COS

<i>Effect Code</i>	<i>Name</i>
MAT	Matt Finish
COS	Cosmojet

The Matt Finish effect is achieved by performing a chemical matting process on the entire surface of the crystal. Small variations in the size of the articles may occur as a result of this chemical process.

Using a special process, the outer facets of Flat Back Roses can be blackened. The Cosmojet effect is only possible for the color Crystal (001).

Colors

 Crystal 001	 Violet 371
 White Opal 234	 Light Amethyst 212
 Light Silk 261	 Smoky Mauve 265
 Silk 391	 Provence Lavender 283
 Light Peach 362	 Light Sapphire 211
 Rosaline 508	 Light Azure 361
 Rose Water Opal 395	 Aquamarine 202
 Vintage Rose 319	 Air Blue Opal 285
 Blush Rose 257	 Sapphire 206
 Light Rose 223	 Capri Blue 243
 Rose Peach 262	 Dark Indigo 288
 Padparadscha 542	 Montana 207
 Indian Pink 289	 Turquoise 267
 Hyacinth 236	 Caribbean Blue Opal 394
 Light Siam 227	 Light Turquoise 263
 Indian Siam*** 327	 Blue Zircon 229
 Rose 209	 Indicolite 379
 Fuchsia 502	 Indian Sapphire 217
 Ruby 501	 Denim Blue 266
 Siam 208	 Black Diamond 215
 Burgundy 515	 Pacific Opal 390
 Garnet 241	 Chrysolite Opal 294
 Amethyst 204	 Chrysolite 238
 Cyclamen Opal 398	 Peridot 214
 Purple Velvet 277	 Erinite 360
 Tanzanite 539	 Fern Green 291

 Dark Moss Green 260
 Emerald 205
 Palace Green Opal 393
 Olivine 228
 Khaki 550
 Greige 284
 Light Grey Opal 383
 Sand Opal 287
 Light Colorado Topaz 246
 Jonquil 213
 Yellow Opal 231
 Light Topaz 226
 Sunflower 292
 Topaz 203
 Tangerine 259
 Light Smoked Topaz 221
 Smoked Topaz 220
 Smoky Quartz 225
 Graphite 253
 Jet 280

Ceramics

 Marbled Light Grey 657
 Marbled Terracotta 655
 Marbled Yellow 652
 Marbled Blue 654
 Marbled Black 653

Effects

 Crystal Silver Shade 001 SSHA
 Crystal Moonlight 001 MOL
 Crystal Aurore Boreale 001 AB
 Crystal Luminous Green* 001 LUMG
 Crystal Golden Shadow 001 GSHA
 Crystal Metallic Sunshine* 001 METSH
 Crystal Rose Gold* 001 ROGL
 Crystal Copper* 001 COP
 Crystal Astral Pink 001 API
 Crystal Red Magma* 001 REDM
 Crystal Antique Pink* 001 ANTP
 Crystal Vitrail Light** 001 VL
 Crystal Paradise Shine 001 PARSH
 Crystal Vitrail Medium** 001 VM
 Crystal Volcano** 001 VOL
 Crystal Lilac Shadow 001 LISH
 Crystal Heliotrope** 001 HEL
 Crystal Bermuda Blue** 001 BBL
 Crystal Metallic Blue* 001 METBL
 Crystal Blue Shade* 001 BLSH
 Crystal Tabac** 001 TAB
 Crystal Scarabaeus Green**** 001 SCGR
 Crystal Iridescent Green* 001 IRIG
 Crystal Dorado* 001 DOR
 Crystal Metallic Light Gold* 001 MLGLD
 Crystal Bronze Shade* 001 BRSH

 Crystal Satin* 001 SAT
 Crystal Light Chrome* 001 LTCH
 Crystal Comet Argent Light* 001 CAL
 Crystal Silver Night** 001 SINI
 Jet Nut* 280 NUT
 Jet Hematite* 280 HEM

Crystal Lacquer<sup>PRO</sup> Effects

 Crystal Powder Yellow* 001 L101
 Crystal Powder Rose* 001 L103
 Crystal Powder Blue* 001 L104
 Crystal Powder Green* 001 L102
 Crystal Powder Grey* 001 L105

Crystal Patina

 Crystal White Patina 001 WHIPA
 Crystal Rose Patina* 001 ROSPA
 Crystal Silver Patina* 001 SILPA
 Crystal Gold Patina* 001 GOLPA
 Crystal Black Patina* 001 BLAPA

Classic Colors: This color range offers a wide choice of traditional Swarovski crystal colors.  
 Exclusive Colors: This color range is offered exclusively by Swarovski.

The listed colors and effects are based on the Color Chart for Round Stones (2016).

The standard assortment of colors and effects may vary per product group. Slight changes in shades are unavoidable. Colors may vary according to cut and shape.

The plating resistance of effects is tested according to Swarovski's plating guidelines (SWAROVSKI.COM/PROFESSIONAL). Customers are advised to carry out their own tests if customers' plating parameters diverge from Swarovski plating guidelines. Details for parameter settings can be found on page 19.

- \* Crystals are not resistant to plating and similar processing.
- \*\* Crystals are resistant to plating only if they are foiled.
- \*\*\* The color Indian Siam is available only for a specific size range. Please refer to the current Collection.
- \*\*\*\* Designed by Jean Paul Gaultier

## Testing the plating-resistance

For testing the plating-resistance of effects, the following parameter settings have to be considered:

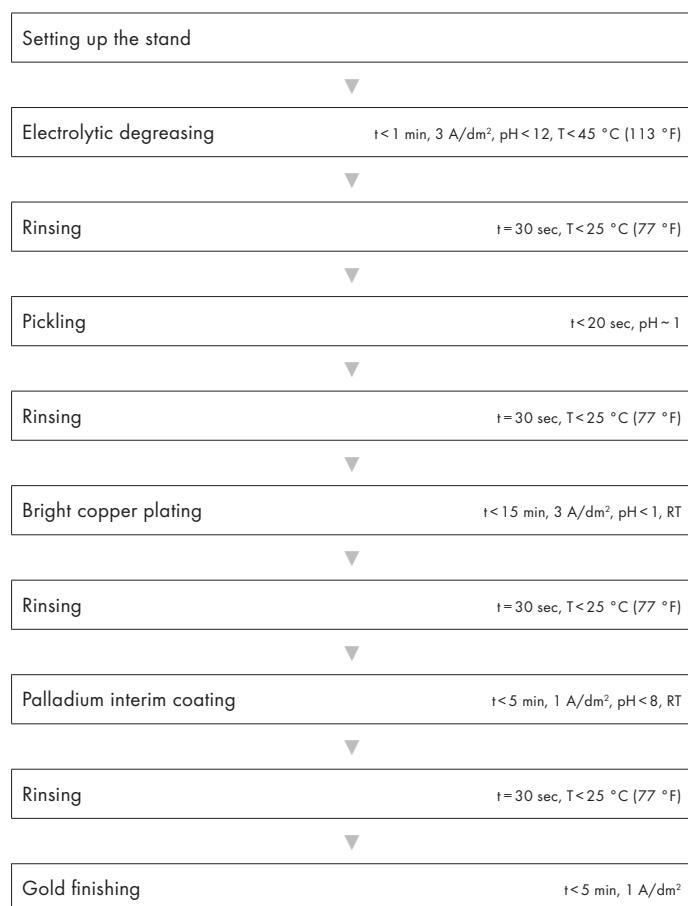

**Note:** Swarovski cannot warrant the resistance of effects when the parameters as set out above are changed. Swarovski's declaration of resistance does not discharge customer from carrying out its own tests of the suitability for the intended finishing of products. The use and processing of these techniques and products are solely the user's responsibility.

**Sizes**

Various measurement abbreviations are used to classify the jewelry stones.



**PP, SS**  
 Pearl Plate (PP), Sieve Size or Stone Size (SS)  
 for round crystals.

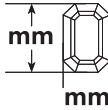

**mm**  
 Metric figures in millimeters for crystal components and  
 geometric forms.

• PP 0 0.70-0.80 mm	• PP 21 (SS 10) 2.70-2.80 mm	• SS 26 5.61-5.78 mm	• SS 45 9.85-10.19 mm
• PP 1 (SS 000) 0.80-0.90 mm	• PP 22 (SS 10) 2.80-2.90 mm	• SS 27 5.78-5.96 mm	
• PP 2 (SS 00) 0.90-1.00 mm	• PP 23 (SS 11) 2.90-3.00 mm	• SS 28 5.96-6.14 mm	• SS 46 10.19-10.54 mm
• PP 3 (SS 0) 1.00-1.10 mm	• PP 24 (SS 12) 3.00-3.20 mm	• SS 29 6.14-6.32 mm	
• PP 4 (SS 1) 1.10-1.20 mm	• PP 25 (SS 13) 3.20-3.30 mm	• SS 30 6.32-6.50 mm	• SS 47 10.54-10.91 mm
• PP 5 (SS 2) 1.20-1.30 mm	• PP 26 (SS 13) 3.30-3.40 mm	• SS 31 6.50-6.68 mm	
• PP 6 (SS 2) 1.30-1.35 mm	• PP 27 (SS 14) 3.40-3.50 mm	• SS 32 6.68-6.87 mm	• SS 48 10.91-11.30 mm
• PP 7 (SS 3) 1.35-1.40 mm	• PP 28 (SS 14) 3.50-3.60 mm	• SS 33 6.87-7.07 mm	
• PP 8 (SS 3) 1.40-1.50 mm	• PP 29 (SS 15) 3.60-3.70 mm	• SS 34 7.07-7.27 mm	• SS 49 11.30-11.72 mm
• PP 9 (SS 4) 1.50-1.60 mm	• PP 30 (SS 15) 3.70-3.80 mm	• SS 35 7.27-7.48 mm	
• PP 10 (SS 4) 1.60-1.70 mm	• PP 31 (SS 16) 3.80-4.00 mm	• SS 36 7.48-7.70 mm	• SS 50 11.72-11.97 mm
• PP 11 (SS 5) 1.70-1.80 mm	• PP 32 (SS 17) 4.00-4.10 mm	• SS 37 7.70-7.93 mm	
• PP 12 (SS 5) 1.80-1.90 mm	• PP 33 (SS 17) 4.10-4.20 mm	• SS 38 7.93-8.16 mm	• SS 55 12.97-13.22 mm
• PP 13 (SS 6) 1.90-2.00 mm	• SS 18 4.20-4.40 mm	• SS 39 8.16-8.41 mm	
• PP 14 (SS 6) 2.00-2.10 mm	• SS 19 4.40-4.60 mm	• SS 40 8.41-8.67 mm	• SS 60 14.22-14.47 mm
• PP 15 (SS 7) 2.10-2.20 mm	• SS 20 4.60-4.80 mm	• SS 41 8.67-8.95 mm	
• PP 16 (SS 7) 2.20-2.30 mm	• SS 21 4.80-4.90 mm	• SS 42 8.95-9.23 mm	• SS 65 15.47-15.72 mm
• PP 17 (SS 8) 2.30-2.40 mm	• SS 22 4.90-5.10 mm	• SS 43 9.23-9.53 mm	
• PP 18 (SS 8) 2.40-2.50 mm	• SS 23 5.10-5.27 mm	• SS 44 9.53-9.85 mm	• SS 70 16.72-16.97 mm
• PP 19 (SS 9) 2.50-2.60 mm	• SS 24 5.27-5.44 mm		
• PP 20 (SS 9) 2.60-2.70 mm	• SS 25 5.44-5.61 mm		• SS 75 17.97-18.22 mm

## SWAROVSKI PRODUCTS AND SUITABLE APPLICATION TECHNIQUES

		Soldering	Plating	Setting	Gluing	Hoflix Application	Sewing	Embroidery	Hand Application	Mechanical Application	Ceralun
Round Stones				✓	✓						✓
Fancy Stones & Settings	Fancy Stones			✓	✓						✓
	Settings	✓	✓	✓			✓ <sup>1</sup>		✓		
Beads							✓ <sup>1</sup>		✓		
BeCharmed & Pavé							✓ <sup>1</sup>		✓		
Crystal Pearls							✓ <sup>1</sup>		✓		
Pendants							✓ <sup>1</sup>		✓		
Flat Backs No Hoflix				✓	✓						✓
Flat Backs Hoflix	XILION Rose & XIRIUS Rose					✓					
	Framed Flat Backs					✓					
	Creation Stones					✓					
	Creation Stones Plus					✓					
	Cabochon Round					✓					
Sew-on Articles							✓	✓ <sup>2</sup>	✓		
Self-adhesive Elements					✓						
Transfers	XILION Transfers & XIRIUS Transfers					✓					
	Creation Transfers					✓					
	Creation Transfers Plus					✓					
	Pearl Transfers					✓					
	Diamond Transfers					✓					
	Metallic Transfers					✓					
	Mezzo Transfers					✓					
Synthetics Hoflix	Crystal Fabric				✓	✓					
	Crystal Rocks & Crystal Fine Rocks				✓	✓					
	Crystaltex				✓	✓	✓ <sup>3</sup>				
Plastic Trimmings	Basic Bandings				✓		✓	✓ <sup>4</sup>			
	Fishnet Bandings						✓				
	Decorative Bandings						✓				
	Plastic Components						✓ <sup>1</sup>		✓		
Buttons, Fasteners & Zippers	Crystal Buttons						✓		✓		
	Buttons with Plastic Shank						✓		✓		
	Snap Fasteners & Decorative Buttons									✓	
	Inset Snap Fasteners & XIRIUS Flat Back Snap Fasteners									✓	
	Jeans Buttons									✓	
	Buttons with Metal Shank						✓		✓		
	Zippers						✓				
Metal Trimmings	Chaton & Flat Back Bandings / Motifs				✓		✓				
	Spike Bandings				✓		✓ <sup>1</sup>				
	Rivets (Crystal Pearl, Square, Chessboard, Star, Spike)									✓	
	Roses & Chaton Montées						✓ <sup>1</sup>		✓		
	Rose Pins, Chessboard Pins & Rhombus Pins									✓	
	Crystal Studs									✓	
Crystal Mesh					✓	✓	✓ <sup>5</sup>				
Cupchains & Findings		✓	✓				✓		✓		

1 These products are not suitable for sewing with a sewing machine 2 Art. 3129 3 Not suitable for Crystaltex Chaton Bandings 4 Art. 50 002, 50 003, and 50 004 (single-row)  
5 Crystal Fine Mesh is not suitable for sewing with a sewing machine



## **SOLDERING, PLATING, AND STONE SETTING**

Swarovski offers an ideal product selection for soldering, allowing for simple and problem-free production of state-of-the-art jewelry pieces and accessories. Further techniques such as plating and stone setting complement the comprehensive and diverse application options offered by Swarovski.

## PRODUCT OVERVIEW

The following products are suitable for soldering, plating, and stone setting:

	SOLDERING	PLATING	STONE SETTING
Round Stones			✓
Fancy Stones			✓
Settings	✓*	✓*	✓
Flat Backs No Hotfix			✓
Cupchains & Findings	✓*	✓*	

\* It is recommended to use the unplated versions (Z).

## MACHINES, TOOLS, AND AIDS

The following machines, tools, and aids can be used for soldering Swarovski crystals:



**Micro soldering kit**



**Propane gas burner**



**Blow torch**



### Solder wire

It is recommended that solder wire with a flux core is used, which guarantees an even flow of solder.



### Solder paste

Solder paste containing flux must be applied at exactly the right spot to create a clean solder joint.



### Solder pellets

Solder pellets should be placed in an acid flux before being used. This ensures that the solder will flow correctly.



### Soldering molds

J-board, express cement



### Polishing machine





Gloves



Protective eyewear

## SUPPLIERS

This list provides an overview of selected suppliers worldwide.

MACHINES / TOOLS / AIDS	SUPPLIER	CONTACT
Micro soldering kit	Horbach	<a href="http://www.horbach-giesstechnik.de">www.horbach-giesstechnik.de</a>
	Rio Grande	<a href="http://www.riogrande.com">www.riogrande.com</a>
Propane gas burner	Horbach	<a href="http://www.horbach-giesstechnik.de">www.horbach-giesstechnik.de</a>
	Rio Grande	<a href="http://www.riogrande.com">www.riogrande.com</a>
Blow torch	Rio Grande	<a href="http://www.riogrande.com">www.riogrande.com</a>
	Siegfried Remschnig	<a href="http://www.remschnig.at">www.remschnig.at</a>
	SRA Soldering Products	<a href="http://www.sra-solder.com">www.sra-solder.com</a>
Solder wire	Alpha	<a href="http://www.alpha.alent.com">www.alpha.alent.com</a>
	Ögussa	<a href="http://www.oegussa.at">www.oegussa.at</a>
	Rio Grande	<a href="http://www.riogrande.com">www.riogrande.com</a>
	SRA Soldering Products	<a href="http://www.sra-solder.com">www.sra-solder.com</a>
Soldering paste	Alpha	<a href="http://www.alpha.alent.com">www.alpha.alent.com</a>
	Ögussa	<a href="http://www.oegussa.at">www.oegussa.at</a>
	Rio Grande	<a href="http://www.riogrande.com">www.riogrande.com</a>
	SRA Soldering Products	<a href="http://www.sra-solder.com">www.sra-solder.com</a>
Solder pellets	Ögussa	<a href="http://www.oegussa.at">www.oegussa.at</a>
	Rio Grande	<a href="http://www.riogrande.com">www.riogrande.com</a>
	SRA Soldering Products	<a href="http://www.sra-solder.com">www.sra-solder.com</a>
Flux	Alpha	<a href="http://www.alpha.alent.com">www.alpha.alent.com</a>
	Ögussa	<a href="http://www.oegussa.at">www.oegussa.at</a>
	Rio Grande	<a href="http://www.riogrande.com">www.riogrande.com</a>
	SRA Soldering Products	<a href="http://www.sra-solder.com">www.sra-solder.com</a>
J-board (solder mold)	SRA Soldering Products	<a href="http://www.sra-solder.com">www.sra-solder.com</a>
Express cement (solder mold)	3M	<a href="http://www.3m.com">www.3m.com</a>
Settings	Swarovski	<a href="http://www.swarovski.com/professional">www.swarovski.com/professional</a>
	E.H. Ashley & Company, Inc.	<a href="http://www.ehashley.com">www.ehashley.com</a>
	Franz Simm Metall- und Zinkdruckgusswaren GmbH	<a href="http://www.simm-metallwaren.de">www.simm-metallwaren.de</a>
	Josef Bergrs GmbH & Co. KG	<a href="http://www.josef-bergrs.de">www.josef-bergrs.de</a>
	Rio Grande	<a href="http://www.riogrande.com">www.riogrande.com</a>

## APPLICATION



A solder mold is required to reproduce jewelry pieces. First the original model of the jewelry piece is soldered. This is then used to make an impression in a suitable impression material (J-board, express cement). Depending on the size of the jewelry piece and mold medium, this impression can be made several times.



1 Solder the original model.

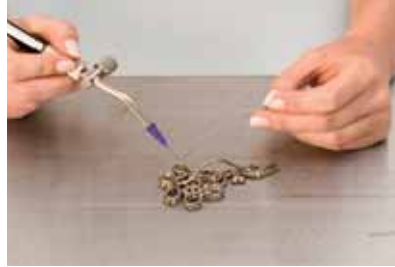

2 Strengthen the rear of the original model with wire.



3 Press the original model into a suitable impression material.



4 Once the material hardens, the original model can be removed.

**Note:** The solder mold must be designed in such a way that hardly any pressure is needed to position the Cupchain segment into the mold. The crystals may be damaged if there are high levels of mechanical stress on the cups, or if they are deformed.

?!  
!

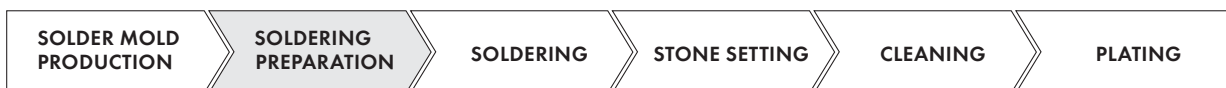

Materials and aids should be clean, and particularly **free of any grease**, to ensure proper application. When soldering and plating, adequate ventilation is essential. In addition, it is recommended that protective clothing, protective eyewear and protective gloves are worn in line with the manufacturer's safety information sheets. Wearing protective gloves also prevents aids from getting dirty. ?!

### Selecting the optimum solder and flux

When selecting solder, the working temperatures and flow characteristics are particularly important. Solder is available from various manufacturers in wire form, with or without a flux core, as a paste and as pellets. ?!

Only soldering alloys with a working temperature up to 280 °C (536 °F) should be used for soldering Cupchains. The higher the working temperature of the solder material used, the more precise workmanship and exact temperature control are necessary to avoid damaging the crystal and the foiling. ?!

When soldering Cupchains, solder wire with a flux core is more suitable. If solder pellets are being processed, or the wire used does not have a flux core, the flux should be adapted according to the solder manufacturer's instructions, while any corrosive effects on the foiling should be checked via pre-testing. These effects should be assessed after plating, as damage done during soldering is often only visible at this point.

For soldering Cupchains we suggest using one of the following lead-free solder wires:

NAME	COMPOSITION	MELTING RANGE	SUPPLIER
Envirosafe	96.5% Sn, 3.45% Cu, 1% Sb, 0.05% Ag	215 - 220 °C 419 - 428 °F	www.sra-solder.com
Silox 227	99% Sn, 1% Cu	227 °C 440 °F	www.oegussa.at



### Soldering time and temperature

The right flame size and the time it is applied are important criteria when manufacturing soldered Cupchain pieces. The size of the flame must comply with the instructions for use provided by the tool's supplier. Only heat the part of the jewelry piece in which the solder should flow. If the flame is held too long on the jewelry piece, the piece and the crystals may become overheated and therefore damaged or destroyed. ?!

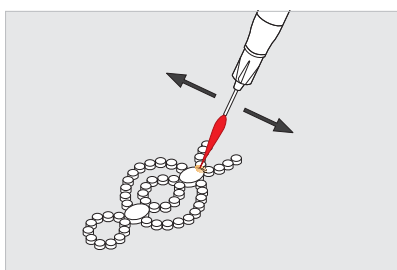

**Note:** A sudden drop in temperature after the soldering process should be avoided (e.g. shock cooling), as this could damage the crystal (e.g. chipping). ?!

**Color during soldering**

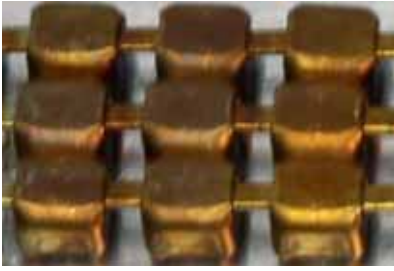

1 Too low temperature

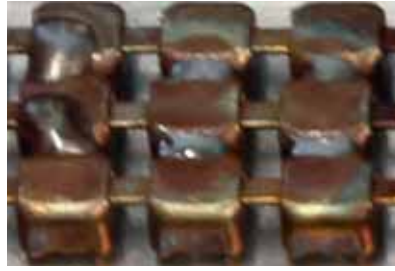

2 Optimum temperature



3 Too high temperature

**Color after soldering**

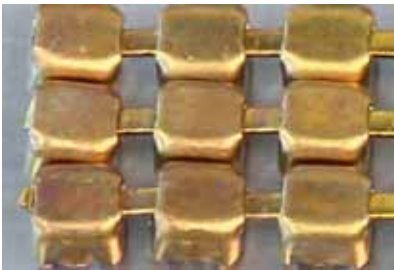

1 Too low temperature



2 Optimum temperature



3 Too high temperature

**Optimum soldering joint**

The width of the joint to be soldered should be between 0.05 mm and 0.2 mm. If the joint is wider than 0.2 mm, the solder will not fill the joint sufficiently. A joint that is too narrow will also not contain enough solder to make it strong and neat.

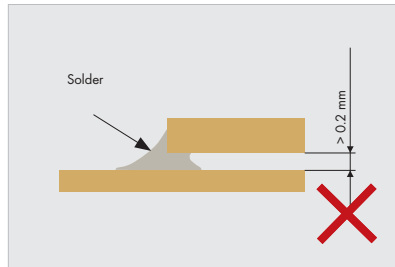
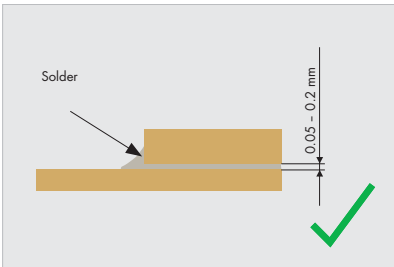

**Optimum solder quantity**

The right amount of solder ensures strong and clean soldered joints, which can then be cleanly plated. Correctly applied solder flows into the joints of the jewelry piece and provides a strong connection. Either too much or too little solder can damage the creations or result in unwanted discoloring of the crystal.

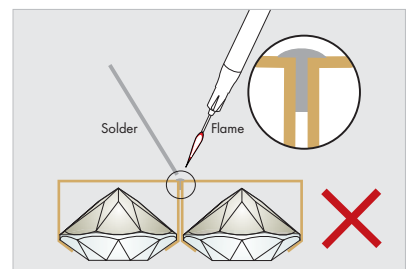
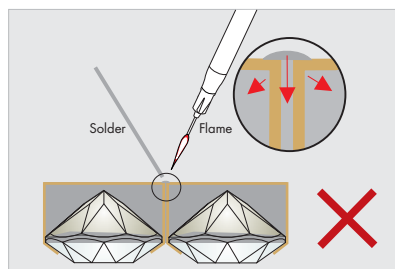
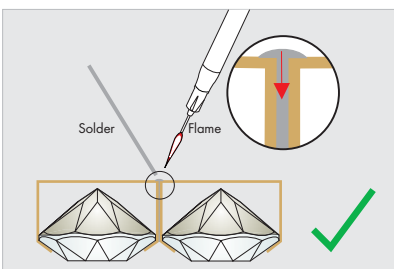



#### Exact amount of solder

The solder is drawn into the solder gap via capillary action.



#### Too much solder

Too much solder results in the cup backfilling, with the hot solder damaging the foiling. This damage creates a corroding surface following plating, and the foiling is destroyed. As such, these types of soldering errors are only really visible after plating.



#### Too little solder

Too little solder means the soldering gap is not completely filled, and the joint is weakened.

## Soldering



1 Cut the Cupchain to the required length.



2 Put the Cupchain in the solder mold.



3 Solder the required spots.



4 Remove the soldered Cupchain from the mold.



Alongside the application methods outlined in this manual, Swarovski products can also be employed using metal settings. Crystals can be set manually (using pliers, metal spatulas, or punching tools) or by machine.

According to how the crystals are integrated into the metal settings, there are various types of settings, both plated and unplated. Whenever possible, the crystals should be set before plating the settings. The Swarovski assortment features products like Cupchains that have already been set, as well as Settings for Fancy Stones. Crystals can be set after plating as well, depending on the shape and geometry of the jewelry. Please be aware that a selected range of Swarovski crystals cannot be plated. For further information on this, please see the current Swarovski Crystal Collection.

## Setting types

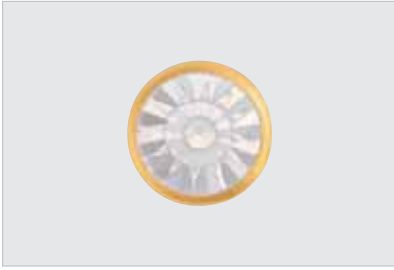

### Bezel settings

With bezel settings, the crystals are bezelled in to remain in the cup.

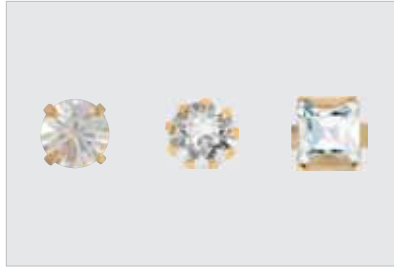

### Prong settings

With prong settings, Swarovski crystals are held in position by claws. In most cases there are four prongs. Settings with flaps have significantly broader claws. The advantage here is that the broader claws are much less likely to damage very sensitive carrier material.



### Settings for gluing

In this type of setting (crystal) elements are glued in.

## Setting by hand

1. Depending on the shape and size, the cup is held using tweezers, flat nose pliers, or flat head pliers, without deforming it.
2. Place the crystal in the setting using a pair of tweezers or vacuum tweezers.
- 3a. Bezel setting: Press the cup shut using a setting closer. Setting closers are available from jewelry suppliers.
- 3b. Prong setting: The prongs of round cups can be pressed in place using a suitable setting closer. For all other forms, the prongs are individually closed in opposite positions, using a suitable pressing tool.

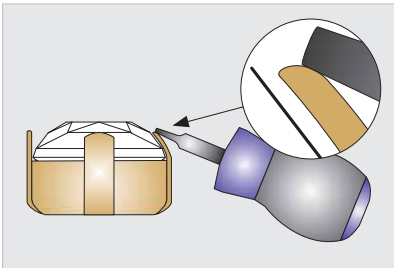

**Note:** After setting, the crystal should still be slightly movable in the setting. The setting must be constructed so that the crystal can be positioned into it without damaging the foiling. When settings are too tight or prongs are bent, the foiling or the protective lacquering can be damaged, possibly resulting in corrosion. If the setting is closed too strongly, the crystal can be damaged.



## Application methods for set crystals

The following application possibilities are available for already set crystals:



### Sewing

Sew-on cups are applied by sewing onto textiles and leather. There are holes in the cups for the thread to pass through.

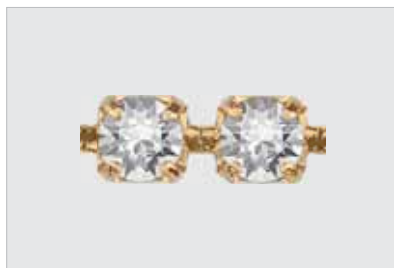

### Soldering

These types of settings are suitable for soldering with other cups and/or with Cupchains. They are mostly used in the jewelry segment.

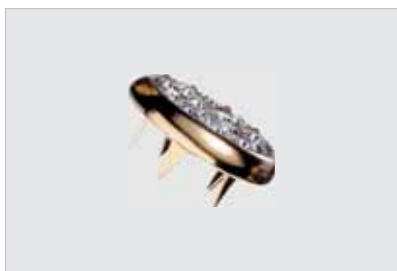

#### Mechanical application

With this special type of setting, the set crystal is applied onto the textile using claws. For more information please consult the corresponding chapter.



#### Threading

Settings that can be used as a pendant have an eyelet at the top, to which a chain can be attached. Settings with two eyelets can be attached to other elements.

### Working with end connectors (brass components)

Plated Cupchains and Findings can easily be combined with end connectors (brass components) in order to create striking pieces of jewelry.



The end connectors can be attached to the end of the Cupchain with flat-nosed pliers and interconnected by either jump rings or lobster claws.

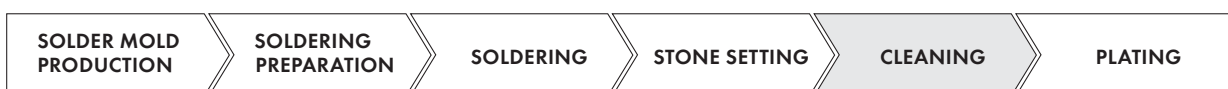

To avoid corrosion, soldered items should be cleaned as soon as possible after the soldering process. This will make the plating process significantly easier. Care must be taken when using mechanical polishing devices. Polishing media that are too hard or drums that rotate too quickly can damage the items and the crystals. Check the quantity, the polishing agents and time, the rotating speed, and the height of the fall, in order to keep mechanical stress levels as low as possible. In order to preserve the high quality of the creations, we recommend not using organic solvents and not exceeding a maximum temperature of 100 °C (212 °F).

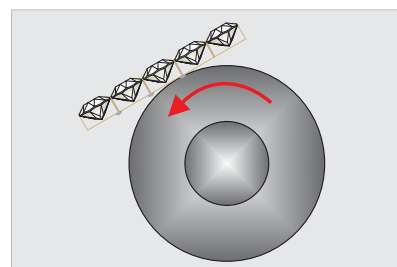

Removal of excessive solder alloy by polishing

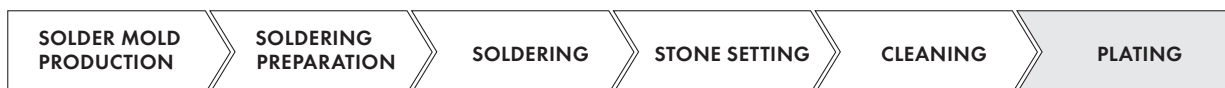

Plating serves to finish the jewelry piece. During this process, metallic coatings are electrolytically added to the surface of the material. The process can only be carried out if the material to be plated is conductive. During the design process, please ensure that individual colors and coating effects can withstand plating. For further information, please see the color overview in the current Swarovski Crystal Collection.

The most important criteria for an excellent finishing process are:

- Selecting reliable electrolyte suppliers who offer good service and who can provide detailed operating instructions
- Selecting suitable high performance electrolytes
- Careful maintenance of the unit and the electrolytes
- Using the recommended settings for plating Cupchains

**Note:** Strong alkaline solutions, long exposure times in alkaline baths, the incorrect use of ultrasound, and high current densities usually lead to chemical and/or mechanical damage to crystals.

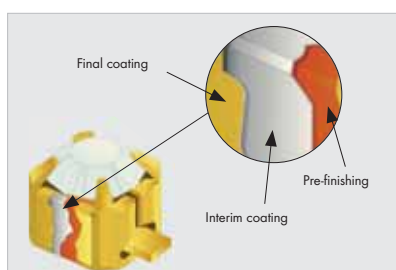

### Short descriptions of the processing steps

- **Hot degreasing:** Here, most of the surface pollution (e.g. dirt, grease, soldering flux) is removed.
- **Electrolytic degreasing:** Only cathodic degreasing, suitable for brass and non-ferrous metals, is recommended for fine cleaning Cupchain jewelry.
- **Pickling:** This part of the process serves to remove oxidization from the metal and also the remains of any scale left from the soldering process.
- **Cyanide copper plating:** This processing step serves to improve adhesive strength and conductivity.
- **Pyrophosphate copper plating:** Like cyanide copper plating, this process improves adhesive strength and conductivity. The advantage is that the process does not involve cyanide, though the disadvantage is that higher current densities and longer exposure times are required.
- **Bright copper plating:** The use of sulfuric bright copper plating is recommended because of its excellent ability to cover surface flaws and create an even finish.
- **Palladium coating:** Palladium is presently the only recommended replacement for nickel since the bronze electrolytes currently available on the market can, through their extreme alkalinity, lead to damage of the foiling.
- **Silver coating:** Shiny silver coatings are usually separated from cyanide solutions that contain alkali silver (I)-cyanide, alkali cyanide, alkali carbonate, and organic and/or inorganic additives.
- **Gold coating:** It is recommended to use phosphorus or citric acid electrolytes (pH ~ 3 - 4), which contain potassium gold (I)-cyanide.
- **Rhodium coating:** Sulfur or phosphoric acid based electrolytes are used for rhodium plating, from which shining, nearly silver-white layers can be applied.
- **Tarnish protection**
  - Temporary protection against tarnishing: These are based either on wax mixtures in organic solvents or long-chained sulfuric organic compounds, which can be used as wet-on-wet aqueous emulsions.
  - Permanent tarnishing protection systems: Cathoretic lacquering systems have been proven especially effective as a longer lasting protective system for Cupchain jewelry. They have the advantage over conventional dipping and spray lacquers based on acrylic or zapon varnish (cellulose lacquer) in that only the conductive surfaces are very evenly coated while the isolated facets of the crystals remain uncoated.



## Parameter settings for plating Cupchains

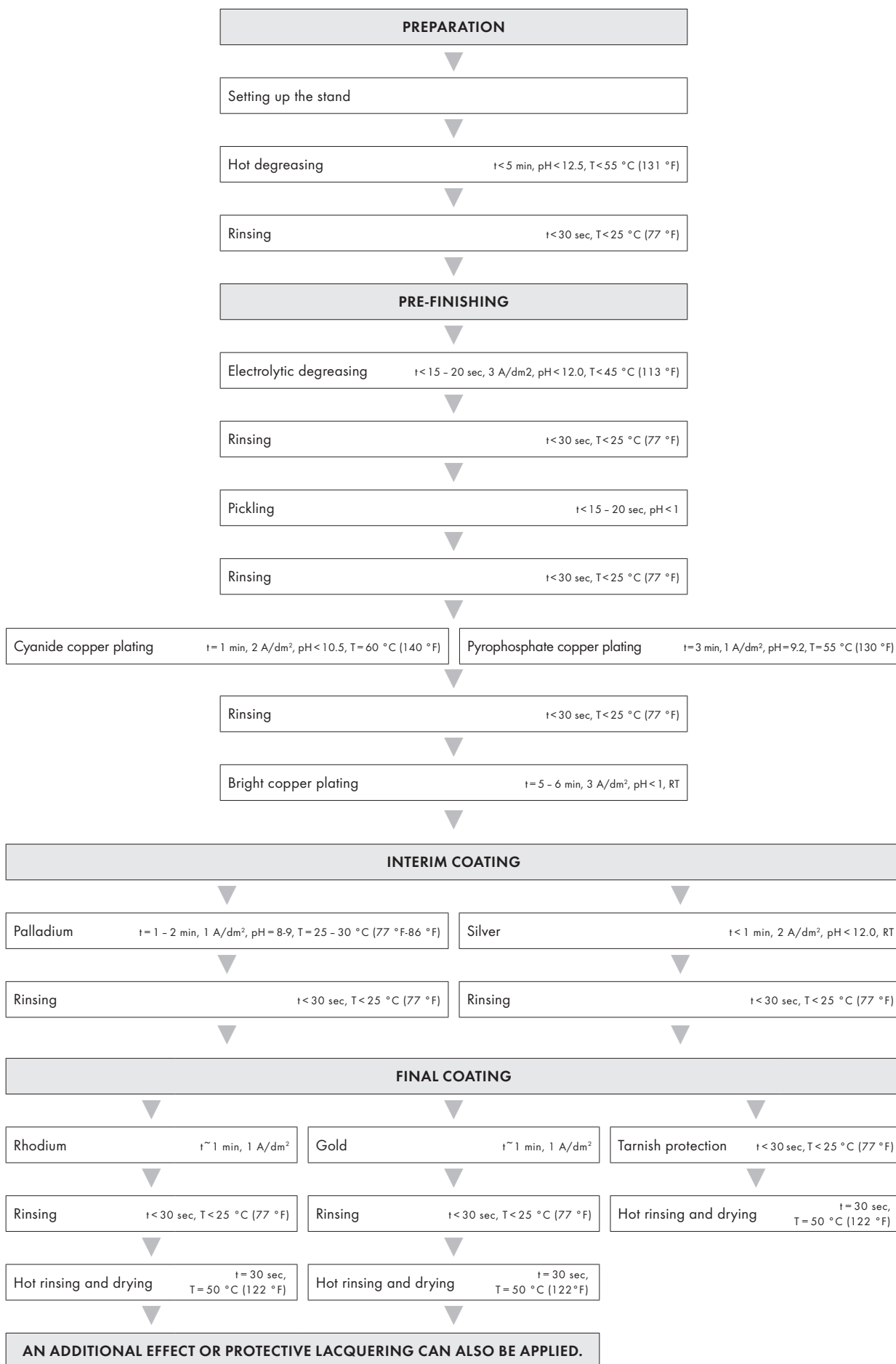

## DIRECTIONS FOR JEWELRY MANUFACTURING

This section offers a brief overview of the ways in which Swarovski products can be integrated into jewelry design software, and a summary of the two most important production techniques for jewelry: rubber mold and lost wax.

### Jewelry design software

Leading software manufacturers offer special programs with three-dimensional display possibilities for the design of jewelry and accessories. These 3D-design programs feature a whole range of functions that simplify and support the design process and therefore also the entire production process.

Special software solutions that have integrated a range of digitally processed Swarovski crystals in their programs are already available ([www.3design.com](http://www.3design.com)). These can be simply and quickly integrated into any design, thus allowing the designer to work with Swarovski crystals right from the beginning of the design phase.

### Production process

#### RUBBER MOLD PROCESSES

This process is widely used in the production of fashion jewelry. Tin alloys are mostly used here, and the biggest advantage of this procedure is the favorable price of the required tools.



1 Several original models are shaped out of metal, which must already exhibit an excellent surface quality. The expected shrinkage during casting must be taken into account.



2 These original models are pressed into a rubber mold. The rubber mold gets vulcanized to create a rubber casting model.



3 Channels are cut in the rubber plate for the casting process.



4 The completed rubber molds are pressed together and filled with the molten metal alloy during rotating (centrifugal casting procedure).



5 After cooling and removing from the mold, the casting channels are cut off.



6 The cast model achieved by this process is ground and polished in preparation for the plating process.

## LOST WAX PROCESS

The lost wax process is used for metals with a higher melting point, for example brass, silver, and gold.



1 Production of a prototype, e.g. through rapid prototyping; the better the surface quality is here, the better the casing will be later. The expected shrinkage during casting must be taken into account.

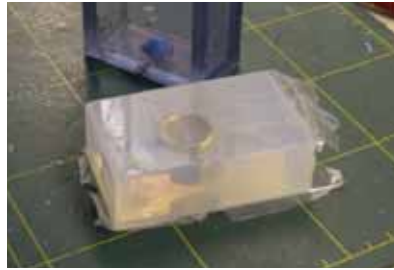

2 The prototype is either formed with silicone or vulcanized between raw rubber plates.



3 The already produced mold is injected with molten wax by a wax injector to create a wax model.



4 The wax forms created this way are each melted onto a wax tree format with a wax welding device. The trunk of the wax tree later serves as the casting channel.



5 The tree is now placed into a cuvette, the holes are glued up and it is embedded in implantation paste under vacuum and vibration.



6 The wax is melted out after the implantation paste has hardened. Remaining wax is burnt out in a kiln. The wax must be completely burnt out, leaving only the clean cavities.



7 While it is still hot, the cuvette is filled, under vacuum, with the molten metal. Because of the porosity of the form, the molten metal fills every part of it.



8 After casting, the hot cuvette is plunged into cold water. The casting tree is then cleaned.



9 After the jewelry pieces are removed from the casting tree, they are finished by grinding and polishing and pre-treated for the galvanization process.

## QUICK ASSISTANCE

The following table outlines common problems and their causes when soldering, plating, and stone-setting Swarovski products, and offers advice on how to avoid them. Further details and more extensive descriptions can be found in the section marked with a **?!**

PROBLEM	CAUSE
<b>Metal components:</b>	
The solder joints crack.	1, 2, 3, 4
The jewelry piece has restricted movement.	2, 5
The metal surface is defective.	2, 6
The metal surface is uneven.	7
Defective finishing on the soldered areas.	8
Corrosion occurs on the metal.	9
<b>Crystal</b>	
The crystal chips off.	10, 11, 12, 13
The crystal becomes discolored.	14, 15, 16, 17

CAUSE	RECOMMENDATION
<b>1</b> Too little solder is used. This weakens the solder joint, as the soldering gap is not completely filled.	Use more solder.
<b>2</b> Too much solder is used. A large solder joint can result in cracks, because any force applied to the piece directly affects the solder.	Use less solder, especially in the areas close to the moving parts. Too much solder at these parts restrict their flexibility.
<b>3</b> The flow of the solder is insufficient.	The following factors contribute to a sufficient flow of solder: <ul style="list-style-type: none"> <li>▪ The flame needs to be strong enough so that both solder and cup can heat up to the required working temperature.</li> <li>▪ To make sure the flux cannot vaporize, the soldering temperature must not exceed 280 °C (536 °F). A vaporized flux means that the solder is not able to cover the metal surface.</li> <li>▪ The melting temperature of the solder must not be higher than 280 °C (536 °F).</li> </ul>
<b>4</b> The metal surface, solder, flux, or solder mold is dirty.	Special attention must be paid to use clean (and above all grease-free) metal surfaces.
<b>5</b> Exposure to the finishing process has been too long.	The exposure time for functional and flexible elements should be kept as short as possible. Optimizing the polishing processes and the use of high quality electrolytes is also recommended.
<b>6</b> Insufficient cleaning after soldering.	Incorrect cleaning has a negative impact on the finishing process. Carefully check the cleaning process.
<b>7</b> Poor quality of polishing. The metal surface shows irregularities like burns or an orange color.	Carefully polish the product and take care that the processor plating baths are set up correctly.
<b>8</b> Unsightly finishing on the solder areas can have several causes: <ul style="list-style-type: none"> <li>▪ incorrect soldering</li> <li>▪ insufficient cleaning after the soldering process</li> <li>▪ the use of sulfuric acid in the pickling process (if lead-containing solder has been used)</li> <li>▪ the absence of or incorrect use of copper plating</li> </ul>	Carefully follow the soldering steps described in this chapter.
<b>9</b> Insufficient rinsing or using contaminated rinsing water can cause tarnishing or corrosion.	The transfer times between the individual stages of the process should be kept as short as possible. Rapid tarnishing of silver can be prevented by using effective tarnishing protective systems (e.g. coatings, wax, lacquer etc.).
<b>10</b> Poor quality of solder mold.	The solder mold must be designed in such a way that hardly any pressure is needed to position the Cupchain segment into the mold. The crystals may be damaged if there are high levels of mechanical stress on the cups, or if the cups are deformed.

CAUSE	RECOMMENDATION
11 Thermal shock during the soldering or cooling process can cause tension in the crystals.	Avoid extreme differences in temperature during and after the soldering and cooling process.
12 When using polishing drums, the surface of the crystals can be damaged through hard polishing components in the rotating machine.	Mechanical stress levels should be kept as low as possible. Check the quantity of articles used, the polishing agents and time, as well as the rotating speed and the height of the fall.
13 Using barrel plating can damage crystals in heavy or sharp Cupchains due to the Cupchains' size or shape.	In general it is recommended that Cupchain jewelry should be finished on a plating rack. If using a barrel plating, choose the best type of drum and optimize the rotation and the fall height. When the drum is between the different stages of the finishing process and contains no liquid, the items being plated inside the drum may damage each other.
14 The soldering temperature is too high.	If the soldering flame is too strong or the soldering times are too long, there is the danger to overheat the solder joints. This can damage the crystals. It can be helpful using a solder that melts at a lower temperature. For more details see the temperature information on page 27 - 28.
15 Too much solder is in the cups. This can damage the crystals' foiling and subsequently leads to discoloring.	To make sure the right amount of solder is used, remove one crystal from the cup. If there is any solder left in the cup, reduce the amount of solder. This can be achieved by using a solder wire with a maximum diameter of 1 mm or by reducing the time the solder is in contact with the cups.
16 Incorrect cleaning with ultrasonic can damage the foiling of the crystals.	Take care not to use the ultrasonic too intensively or for too long time.
17 Faults occurred during the finishing process.	Check the alkalinity, current density, exposure times, and temperatures of the plating baths used. Further mistakes could be incorrect rinsing and post processing techniques.



# GLUING

Swarovski products can be glued to a wide range of materials in a variety of application areas. The greatest quality is ensured by following the entire application process.

## PRODUCT OVERVIEW

The following products are suitable for gluing:

	GLUING
Round Stones	✓
Fancy Stones	✓
Flat Backs No Hotfix	✓
Self-adhesive Elements	✓
Synthetics Hotfix	✓
Plastic Trimmings: Basic Bandings	✓*
Metal Trimmings: Chaton & Flat Back Bandings/Motifs, Spike Bandings	✓
Crystal Mesh	✓

\* Plastic Trimmings made of PE or PP are not suitable for gluing.

## MACHINES, TOOLS, AND AIDS

The following machines, tools, and aids can be used for the various processes involved in gluing Swarovski products:



CNC milling machine



Box column drill



Hand drill

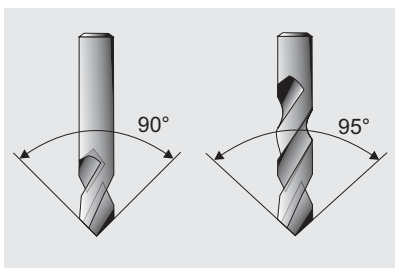

Twist drill 90° /  
NC drill 90°  
for XILION Chatons

Twist drill 95° /  
NC drill 95°  
for XIRIUS Chatons

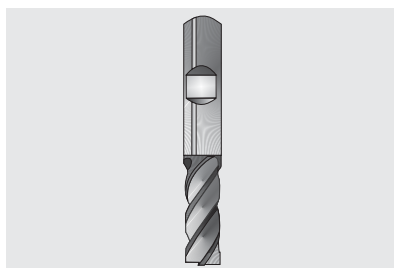

Milling cutter





Test Pen (art. 9030/000)



Isopropyl alcohol/Acetone



Blow torch



Corona



Plasma cleaner



Precision balance



Gloves



Protective eyewear



Dispensing robot



Fluid dispenser

Courtesy of I&J Fisnar, Inc.



Dispensing gun



Dispensing syringes with dispensing tips



Mixing Nozzle



**CG 500 (A+B)**  
Two-component epoxy resin glue: 50 g cartridge (25 g component A, 25 g component B)



**CG 500 (A+B)**  
Two-component epoxy resin glue: 100 g tube (50 g component A, 50 g component B)



**CG 500 (A+B)**  
Two-component epoxy resin glue: 2 kg tin (1 kg component A, 1 kg component B)



**Different glues**



**CG 610 (A+B)**  
Two-component epoxy resin glue: 50 g cartridge (33.3 g resin + 16.7 g hardener)



**CG 610 (A+B)**  
Two-component epoxy resin glue: 750 g box (500 g resin + 250 g hardener)



**Chaton Sieve** for Chatons size PP 0 - PP 1 (art. 9030/003)



**Chaton Sieve** for Chatons size PP 2 - PP 20 (art. 9030/001)



**Chaton Sieve** for Chatons size PP 21 - SS 34 (art. 9030/002)



**Vacuum pick-up system**

Courtesy of I&J Fisnar, Inc.



**Tweezers**



**Wax stick**



**UV light**



**Drying oven**

## SUPPLIERS

This list provides an overview of selected suppliers worldwide.

MACHINES / TOOLS / AIDS	SUPPLIER	CONTACT
90° NC drill/milling cutter	Dixi Holding SA	<a href="http://www.dixi.ch">www.dixi.ch</a>
	Hahn & Kolb GmbH	<a href="http://www.hahn-kolb.de">www.hahn-kolb.de</a>
	Hoffmann GmbH	<a href="http://www.hoffmann-group.com">www.hoffmann-group.com</a>
	reich Präzisionswerkzeuge	<a href="http://www.reich.at">www.reich.at</a>
	Wedco	<a href="http://www.wedco.at">www.wedco.at</a>
Test Pen	Swarovski: art. 9030/000	<a href="http://www.swarovski.com/professional">www.swarovski.com/professional</a>
Fluid dispenser (with/without vacuum suction)	Epoxy & Equipment Technology Pte Ltd	<a href="http://www.eet.com.sg">www.eet.com.sg</a>
	Hottemp (M) Sdn. Bhd.	<a href="http://www.hottemp.com.my">www.hottemp.com.my</a>
	I & J Fisnar, Inc.	<a href="http://www.fisnar.com">www.fisnar.com</a>
	PT. SKT International	<a href="http://www.sktisolution.com">www.sktisolution.com</a>
	Vieweg GmbH	<a href="http://www.dosieren.de">www.dosieren.de</a>
Vacuum pick-up system	Epoxy & Equipment Technology Pte Ltd	<a href="http://www.eet.com.sg">www.eet.com.sg</a>
	I & J Fisnar, Inc.	<a href="http://www.fisnar.com">www.fisnar.com</a>
	Vieweg GmbH	<a href="http://www.dosieren.de">www.dosieren.de</a>
CG 500 (A+B) Two-component epoxy resin glue	Swarovski:	<a href="http://www.swarovski.com/professional">www.swarovski.com/professional</a>
	art. 9030, 50 g Cartridge, America, Asia, Europe	
	art. 9030, 100 g Tube, America, Asia, Europe	
	art. 9030, 2 kg Box, America, Asia, Europe	
CG 610 (A+B) Two-component epoxy resin glue	Swarovski:	<a href="http://www.swarovski.com/professional">www.swarovski.com/professional</a>
	art. 9030, 50 g Cartridge, America, Asia, Europe	
	art. 9030, 750 g Box, America, Asia, Europe	
Mixing nozzle for CG 500 and CG 610	Swarovski: art. 9030/126	<a href="http://www.swarovski.com/professional">www.swarovski.com/professional</a>
Araldite® adhesives	Huntsman International LLC.	<a href="http://www.huntsman.com/advanced_materials">www.huntsman.com/advanced_materials</a>
3M™ Scotch-Weld™ adhesives	3M	<a href="http://www.3m.com">www.3m.com</a>
DELO adhesives	DELO Industrial Adhesives	<a href="http://www.delo.de">www.delo.de</a>
ELASTOSIL® adhesives / MS Clear HS	Wacker Chemie AG	<a href="http://www.wacker.com">www.wacker.com</a>
LOCTITE® adhesives	Henkel Ltd.	<a href="http://www.loctite.com">www.loctite.com</a>
Hobby Line Schmuckstein Kleber	C. KREUL GmbH & Co KG	<a href="http://www.c-kreul.com">www.c-kreul.com</a>
CHRISANNE glues	CHRISANNE Ltd	<a href="http://www.chrisanne.com">www.chrisanne.com</a>
Bostik 1475	Bostik SA	<a href="http://www.bostik.com">www.bostik.com</a>
UHU plus endfest 300	UHU GmbH & Co KG	<a href="http://www.uhu.com">www.uhu.com</a>
Tile glues / joint sealers	PCI Augsburg GmbH	<a href="http://www.pci-augsburg.de">www.pci-augsburg.de</a>
	KERAKOLL Spa	<a href="http://www.kerakoll.com">www.kerakoll.com</a>
	ARDEX GmbH	<a href="http://www.ardex.com">www.ardex.com</a>

MACHINES / TOOLS / AIDS	SUPPLIER	CONTACT
Chaton Sieve	Swarovski: For Chaton size PP 0 – PP 1: art. 9030/003 For Chatons size PP 2 – PP 20: art. 9030/001 For Chatons size PP 21 – SS 34: art. 9030/002	<a href="http://www.swarovski.com/professional">www.swarovski.com/professional</a>
Pick-up stick	Crystal Ninja	<a href="http://www.crystalkatana.com">www.crystalkatana.com</a>
UV light	DELO Industrial Adhesives Dr. Hönle AG Heraeus Holding GmbH Herbert Waldmann GmbH & Co. KG	<a href="http://www.delo.de">www.delo.de</a> <a href="http://www.hoenle.de">www.hoenle.de</a> <a href="http://www.heraeus.com">www.heraeus.com</a> <a href="http://www.waldmann.com">www.waldmann.com</a>
Drying oven	Heraeus Holding GmbH VWR International, LLC.	<a href="http://www.heraeus.com">www.heraeus.com</a> <a href="http://www.vwr.com">www.vwr.com</a>

---

## APPLICATION

When gluing Swarovski crystals, optimal results are obtained by **coordinating the entire application process**. Following the application steps in the right order is very important. Experience has shown that the most common reasons for crystals becoming detached are inappropriate areas of application, poorly produced cavities, unsuitable gluing systems, and insufficient quantities of glue. **Product-specific application instructions** are detailed later in this section.



Many Swarovski crystals require cavities in order to be applied to materials. A properly produced cavity in combination with a suitable gluing system ensures a stylish, long-lasting application. The cavity makes it easy to glue properly and ensures higher **protection of the crystal against mechanical and chemical stress**. There are several different production methods and cavity types. Always take into consideration the requirements and base material of the finished product when choosing the appropriate cavity, pre-treatment method, and kind of glue.

### Production methods

- **Drilling** is when materials are machined using a power drill and drilling tool.
- **Milling** is when materials are machined using a milling machine and milling cutter. Milling machines can be fitted with appropriate tools depending on the materials, e.g. for working with metal and plastic, wood, or natural stone. Modern CNC machining centers offer the greatest precision and can be used to produce **cavities of every shape** necessary. Please note that when machining natural stone, ceramic, or glass, for example, special diamond-tipped tools must be used.
- **Water jet cutting** allows materials to be separated via a high-pressure jet of water. Economic reasons make water jet cutting machines ideal for certain crystal shapes that are integrated into flat materials. Please note that only **end-to-end cavities** can be produced in this way. In addition, materials that swell through water cannot be worked with. Absorbent materials must be fully dried before gluing the crystal.
- **Casting:** To reproduce cavities, particularly in the jewelry sector, the cavities can be made when the metal component is cast. When following this process, the cavities must be cut into the original model. To prevent the bottom of the cavity being rounded off, which would result in the crystal sitting too high, it is recommended that an additional indentation is made when producing the original model.

Further instructions on jewelry production can be found on page 34.

## Cavity types

Depending on the Swarovski products used, various cavity types can be made using the different production methods.

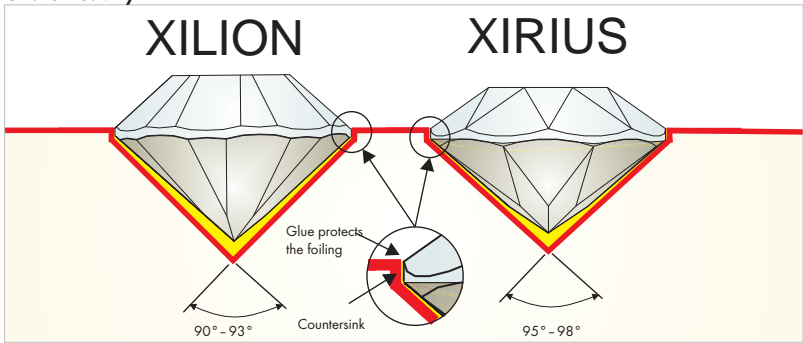
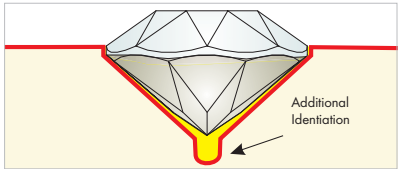
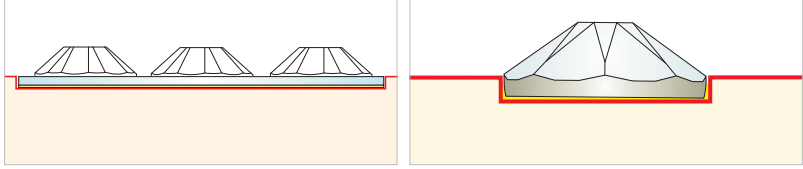
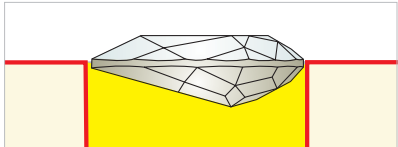
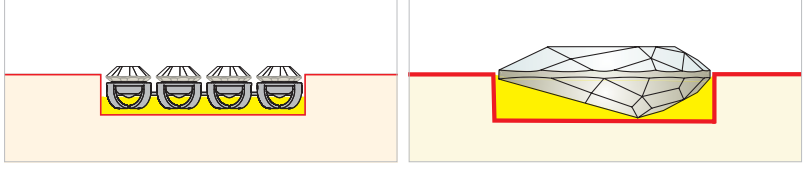
SWAROVSKI PRODUCTS	PRODUCTION METHOD	CAVITY TYPE
Round Stones	Drilling Milling	<p><b>Chaton cavity</b></p>  <p>The optimal cavity for a XIRIUS Chaton is produced at an <b>angle of 95° – 98°</b>, for a XILION Chaton at <b>90° – 93°</b>. The cavity should have the same maximum diameter as the crystal plus at least 0.1 mm. The stone sizes available for Swarovski crystals can be found on page 19. For particularly large crystals with a prominent girdle, it is advisable to use an additional countersinking process. Please find a cavity calculator on <a href="http://SWAROVSKI.COM/PROFESSIONAL">SWAROVSKI.COM/PROFESSIONAL</a>.</p>
Round Stones	Casting	<p><b>Chaton casting cavity</b></p>  <p>For jewelry manufactured by casting, an <b>additional indentation</b> at the bottom of the cavity can be drilled to avoid a rounded tip, therefore preventing the crystal from being raised out of the cavity.</p>
Flat Backs No Hotfix Crystal Fabric Crystaltex Self-adhesive Elements Crystal Rocks Crystal Fine Rocks	Milling Casting	<p><b>Indentation</b></p>  <p>When gluing Swarovski crystals with a <b>Flat Back</b>, it is also advisable to create a cavity as shown here. This cavity ensures that the crystal is better protected against mechanical and chemical stress. The depth of the cavity depends on the height of the girdle and the strength of the base material.</p>
Round Stones Flat Backs No Hotfix Fancy Stones	Drilling Milling Water jet cutting	<p><b>End-to-end cavity</b></p>  <p>An end-to-end cavity is the <b>simplest option</b> when producing cavities. When selecting the glue (page 48), please note the additional instructions regarding the gluing gap.</p>
Plastic Trimmings Crystal Mesh Fancy Stones	Milling Casting	<p><b>Blind hole</b></p>  <p>A blind hole is another option when producing cavities. It allows Swarovski crystals in a variety of heights to be set and protected in the material. When selecting the depth of the cavity, ensure that there is still a <b>gap</b> between the lowest point of the crystal and the base material. When selecting the glue (page 48), please note the additional instructions regarding the gluing gap.</p>

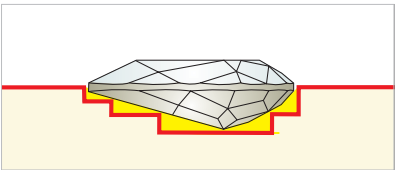
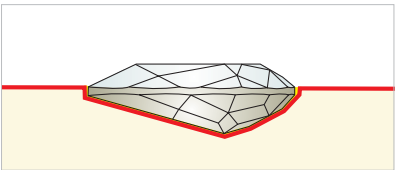
SWAROVSKI PRODUCTS	PRODUCTION METHOD	CAVITY TYPE
Fancy Stones	Milling Casting	<p><b>Step milling</b></p>  <p>Compared to a simple blind hole, step milling offers <b>better hold</b> of the crystal with less glue. When selecting the depth of the cavity, ensure that there is still a gap between the lowest point of the crystal and the base material. When selecting the glue (page 48), please note the additional instructions regarding the gluing gap.</p>
Fancy Stones	Milling Casting	<p><b>3D milling</b></p>  <p>3D milling offers an <b>optimum fit</b> with the smallest gluing gap. Due to the fact that the cavity is adapted to the contours of the crystal, CNC milling machines are required.</p>

**Production tolerances for cavities**

When producing cavities, the dimensions should be based on the main dimensions, including the maximum tolerance for the crystal components used, and the production tolerance. These dimensions can be requested from your Swarovski sales organization.

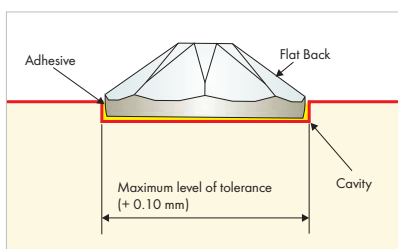

**Incorrect cavities**

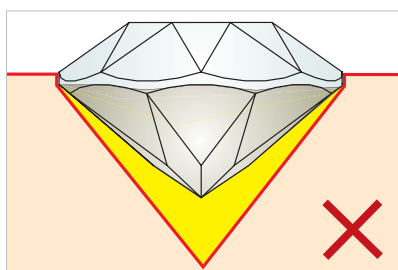

Angle too sharp

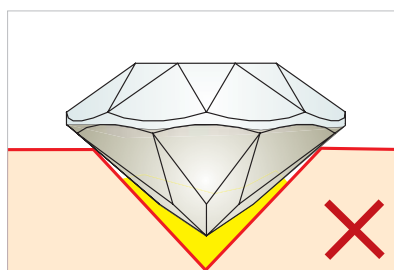

Crystal too large/cavity too small

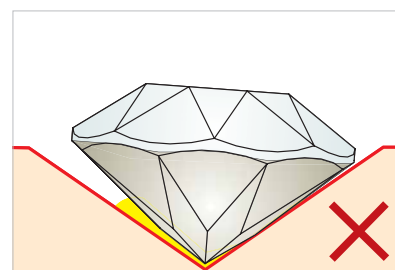

Angle too large

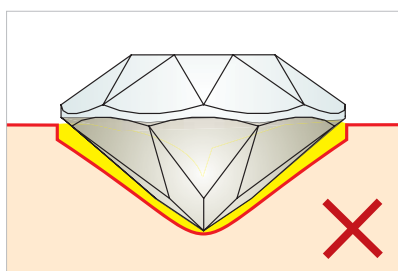

Rounded tip of the cavity

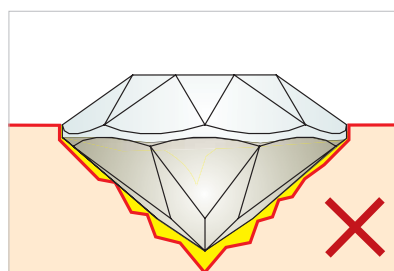

Cavity with uneven surface

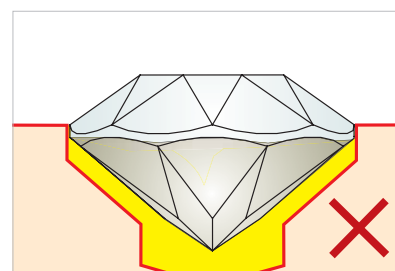

Gap too big

### Checking the surface tension

The surface tension is an indicator for the wetting properties of the surface to be glued. A surface tension of **at least 38 mN/m** is recommended for gluing Swarovski crystals. It should also be randomly tested during production. It is best to use the Test Pen (art. 9030/000) to measure the surface tension.



1 Before gluing, mark the surface.



2 If the ink remains visible for 2 seconds, the surface is suitable for gluing.



3 If the ink disappears or forms bubbles, the surface is not suitable for gluing. In this case, the pre-treatment cleaning methods should be checked.

**Note:** On porous or absorbent materials, the surface tension cannot be checked with the Test Pen. If the Test Pen is used on highly polluted surfaces (e.g. grease, oil) or on material like wood, the Test Pen might be polluted as well and cannot be used anymore.

### Pre-treatment

If the surface tension is below 38 mN/m, the following pre-treatment cleaning methods, applied in the correct order, can be effective in reaching the right level. After each cleaning process, the surface tension has to be checked again.



TYPES OF CLEANING		PRE-TREATMENT CLEANING METHODS
1	<p><b>Mechanical cleaning</b></p> <p>This involves sanding, blasting, or brushing but is usually not necessary for jewelry.</p>	<ul style="list-style-type: none"> <li>▪ Removal of dirt, rust, scale, and residues of varnish</li> <li>▪ Roughening the surface</li> </ul>
2	<p><b>Washing and degreasing</b></p> <p>It is important to ascertain that the tensides do not contain silicone, as this would impair adhesion.</p> <p>When using solvents it is advisable to test the durability of the surface to be cleaned beforehand to avoid any damage. <b>Solvents containing substances with a high boiling point should not be used</b> due to the risk of residue. If using cleaning solvents, wait a few minutes to allow them to evaporate.</p>	<ul style="list-style-type: none"> <li>▪ Cleaning with tenside solutions, rinsing with de-ionized water</li> <li>▪ Cleaning with isopropyl alcohol/ethanol</li> <li>▪ Cleaning with acetone (MEK/ethyl acetate)</li> <li>▪ Cleaning with a cleaning solvent: should not contain high boiling point substances (risk of residue)</li> </ul>



TYPES OF CLEANING		PRE-TREATMENT CLEANING METHODS
<p><b>3 Physical cleaning and activation</b></p> <p>These cleaning methods can be applied if mechanical cleaning or washing and degreasing are either not possible or have not resulted in a surface tension of &gt;38 mN/m. Therefore the pre-treatment cleaning method used should be done on a case-by-case basis.</p>	<ul style="list-style-type: none"> <li>▪ <b>Flame treatment via a blow torch</b> The surface to be treated is exposed to the flame of a torch very briefly. When using special gas mixtures, surface silication can also be carried out, so as to apply a more adhesive coating.</li> <li>▪ <b>Corona treatment</b> An electric corona discharge is briefly applied to the surface.</li> <li>▪ <b>Plasma treatment</b> Plasma treatment offers precise cleaning and activates the surface via an ionized gas.</li> </ul>	
<p><b>4 Chemical cleaning and primers</b></p> <p>Applying a primer improves adhesion and helps to prevent corrosion.</p>	<ul style="list-style-type: none"> <li>▪ Applying small amounts of solvent and activating the surface.</li> <li>▪ Applying a primer.</li> </ul>	



The selection of the best gluing system is the next stage in ensuring a long-lasting application. When selecting the most suitable glue, the following factors should be considered:



- The type of cavities/the resulting gluing gap
- The size of the crystals/gluing surface
- The gluing properties and finish required
- The type of base material

#### The type of cavities/the resulting gluing gap

When selecting an adhesive, it is also important to consider the gluing gap that results from the type of cavity chosen. For cavities offering a **large gluing gap, soft and gap-filling** glues such as silicone glue are recommended to avoid tension in the glue joint.

Epoxyethane/polyurethane glues offer **greater strength** and can be used for cavities with a **small gluing gap**.

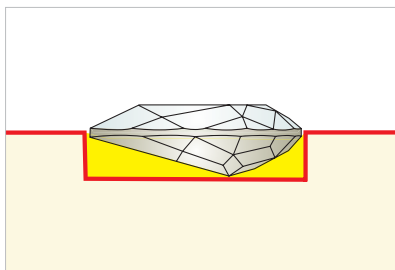

Large gluing gap

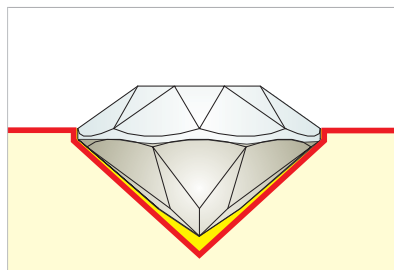

Small gluing gap

#### The size of the crystals/gluing surface

Please note that when gluing small crystals, glues with higher shearing strengths (e.g. epoxy resin glue CG 500 (A+B)) should be used. Further information can be found in the manufacturer's technical data sheets.

### The gluing properties and finish required

When selecting glues, it is important to consider properties such as **pot life, viscosity, color, curing time, ease of dosing, and shrinkage**. Further information can be found in the manufacturer’s technical data sheets. Adhesives tend to shrink during curing. There will be a greater amount of **shrinkage** if the wrong glue has been chosen, it is hardened under the wrong conditions, or if there is an incorrectly sized cavity (too much space around the crystal). The tension thus created can damage the foiling and the crystals may even detach. Glues that are very hard after curing and shrink considerably are not suitable for Swarovski crystals with foiling.

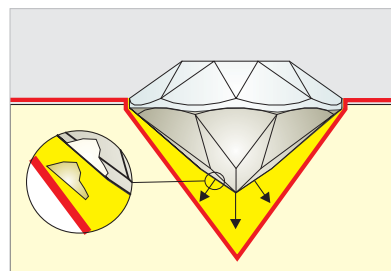

The foiling is torn from the crystal because of excessive **glue shrinkage** (shown in yellow).

### The type of base material

The following table provides a selection of commonly known and globally available adhesives that are suitable for different uses and materials. Application tests are advisable to make sure the chosen glue fulfills the specific needs of your application.

**Viscosity:** Measure of a fluid’s resistance to gradual deformation by shear/tensile stress. It corresponds to the informal notion of “thickness”.

**Color:** Description of the glue’s color type after curing.  
**Bonding:** Depending on the carrier material, the bonding of the glues can vary.

#### Viscosity types

low	thin fluid
med	medium
high	pasty

#### Bonding types

+	sufficient or excellent bonding can be reached
o	sufficient bonding is possible
-	sufficient bonding is nearly impossible

	TWO-COMPONENT EPOXY RESIN GLUES						POLYURETHANE GLUES			CYANE-ACRYLATE GLUES	UV GLUES		SILICONE GLUES	ONE-COMPONENT SYSTEM	DOUBLE SIDED TAPES	DISPERSIONS & CONTACT GLUE		
	CG 500 (A+B)	CG 610 (A+B)	UHU plus endfest 300	Araldite® 2011	DELO-DUOPOX AD821	3M™ Scotch-Weld™ DP 190	Araldite® 2028-1	3M™ Scotch-Weld™ DP 610	DELO-PUR 989.5	LOCTITE® 401™	DELO-PHOTOBOND GB368	DELO-PHOTOBOND 4494	ELASTOSIL® N 2199	DELOMONOPOX AD066	3M™	Hobby Line Schmuckstein Kleber	Bostik 1475	CHRISANNE
Color	translucent	translucent	beige	beige	beige	white/gray	transparent	transparent	beige	transparent	transparent	transparent	transparent	beige	transparent	transparent	beige	white
Viscosity	med	low	high	high	med	high	low	high	high	low	med	med	high	med	-	med	high	high
Crystal	+	+	o	+	+	+	o	o	o	-	+	+	-	+	o			
Glass	+	+	o	+	+	+	o	o	o	-	+	+	-	o	o			
Ceramics	+	+	-	o	+	+	+	+	+	-	-	-	o	o	o			
Stone	+	+	-	o	+	+	+	+	+	-	-	-	o	o	o			
Aluminum	+	+	+	+	+	+	+	+	+	o	+ <sup>1</sup>	+ <sup>1</sup>	o	+	o			
Brass	+	+	+	+	+	+	+	+	+	o	+ <sup>1</sup>	+ <sup>1</sup>	o	+	o			
Silver	+	+	+	+	+	+	+	+	+	o	+ <sup>1</sup>	+ <sup>1</sup>	o	+	o			
Steel	+	+	+	+	+	+	+	+	+	o	+ <sup>1</sup>	+ <sup>1</sup>	o	+	o			
PC	+	+	-	o	+	+	o	o	o	+	o <sup>1</sup>	+ <sup>1</sup>	o	-	o			
PS	+	+	-	o	+	+	o	o	o	+	o <sup>1</sup>	o <sup>1</sup>	o	-	o			
PVC/ABS	+	o	-	o	+	+	o	o	o	+	o <sup>1</sup>	o <sup>1</sup>	o	-	o			
PMMA	+	o	-	o	+	+	o	o	o	+	+ <sup>1</sup>	o <sup>1</sup>	o	-	o			
Paper	o	o	-	o	o	o	o	o	o	o	-	-	o	-	o	o	o	o
Cork	o	o	-	o	o	o	o	o	o	-	-	-	o	-	o			
Wood	o	o	-	o	o	o	o	o	o	-	-	-	o	-	o			
Textiles <sup>2</sup>	-	-	-	-	-	-	-	o	-	-	-	-	-	-	-	o	o	o

<sup>1</sup> The second gluing part has to be UV transparent. <sup>2</sup> For permanent (wash-resistant) application a Hotfix application is suggested.

### CG 500 (A+B) Two-component epoxy resin glue

CG 500 (A+B) is a high-performance gluing system for both foiled and unfoiled Swarovski crystals, exclusively distributed by Swarovski for professional use within the jewelry segment and other industries such as accessories, interiors, and electronics.

#### Main advantages of CG 500 (A+B)

- Ideal mechanical resistance
- Ideal chemical resistance
- Future-oriented solution
- Diverse areas of application

#### IDEAL MECHANICAL RESISTANCE

CG 500 (A+B) **absorbs impacts and withstands distortion**. In addition, maximum elasticity protects the crystal foiling.



XILION Chatons that have been glued with CG 500 (A+B) remain in the cavities after extreme mechanical stress due to **optimal shock absorbance** (up to 500%).



XILION Chatons that have been glued with a **standard epoxy resin** fall out of their cavities after extreme mechanical stress due to its **poor shock absorbance** (around 10%).

#### IDEAL CHEMICAL RESISTANCE

CG 500 (A+B) OFFERS EXCELLENT CHEMICAL RESISTANCE AGAINST:	
Humidity	CG 500 (A+B) prevents infiltration of humidity into the glue and thus any corrosion. Jewelry pieces can be stored and worn in places with high humidity.
Perspiration	CG 500 (A+B) prevents infiltration of perspiration into the glue and thus avoids corrosion. The glued Swarovski products are not damaged by perspiration.
Salt and chlorinated water	CG 500 (A+B) protects Swarovski crystals when they are exposed to salt or chlorinated water. The glued Swarovski products are not damaged during swimming.

## DIVERSE AREAS OF APPLICATION

<b>CG 500 (A+B) OFFERS IDEAL ADHESION FEATURES ON:</b>	
Metals	E.g. Application of Swarovski products on plated surfaces, brass, stainless steel, titanium, gold, rhodium, and silver within the jewelry industry
Gluable synthetics and rubber	E.g. Application of Swarovski crystals on ABS, PMMA, PVC etc. within the accessories and electronics industries
Glass, crystal, wood, stone, cork, and porcelain	E.g. Application of Swarovski products in the interior and home décor industries

### CG 500 (A+B) technical data

Mixture ratio (A:B)	1:1 (by weight)
Pot life at room temperature (23 °C/73.4 °F), quantity applied: 1 g	15 min.
Complete curing time at room temperature (23 °C/73.4 °F)	24 h
Complete curing time in oven (40 °C/104 °F)	12 h
Complete curing time in oven (70 °C/158 °F)	2 h
Complete curing time in oven (100 °C/212 °F)	1 h
Handling time at room temperature (23 °C/73.4 °F)	3 h
Elasticity	500%
Viscosity (mixed)	15.000 +/- 5.000 mPa*s

### Mixing CG 500 (A+B) two-component glue

The exact mixing of the two-component glue is especially important. Only a fully homogenous mixture leads to the desired results. Care must be taken to follow the manufacturer's instructions.



1 Weigh out the two glue components at a ratio of 1:1.



2 Mix the two components until a homogenous result is achieved.



3 Put the glue in a dispenser.



4 Attach the dispensing tip to the syringe.

## CG 610 (A+B) two-component epoxy resin glue

The CG 610 (A+B) two-component epoxy resin glue was specially developed for gluing Swarovski crystals of very small sizes, starting with PP 0. Depending on the area of application the adhesive can be used for crystals up to the size of PP 14.

### Key Features:

- Suitable for gluing very small crystals (starting with size PP 0)
- Low viscosity allows an easier dosing of small glue quantities
- Cost saving due to long pot life (140 min.)

### Available Packaging Sizes

The CG 610 (A+B) adhesive is available in the following two packaging sizes and in two regional versions\*:



**CG 610 (A+B) 50 g cartridge**  
(33.3 g resin + 16.7 g hardener)  
(Europe/America/Asia)



**CG 610 (A+B) 750 g box**  
(500 g resin + 250 g hardener)  
(Europe/America/Asia)

\*Please note: The composition of the adhesive is the same for both versions; the different description on the packaging is due to local legal requirements. It is mandatory to order accordingly.

### Technical Data

Mixing ratio (A : B)	2 : 1 (resin : hardener) by weight
Pot life at room temperature (23 °C/73.4 °F) – quantity applied: 1 g	140 min.
Complete curing time at room temperature (23 °C/73.4 °F)	72 h
Complete curing time in oven (40 °C/104 °F)	12 h
Complete curing time in oven (70 °C/158 °F)	4 h
Complete curing time in oven (100 °C/212 °F)	1.5 h
Handling time at room temperature (23 °C/73.4 °F)	16 h
Elasticity (break extension at 23 °C/73.4 °F)	46.5 %
Viscosity, mixed (23 °C/73.4 °F)	1.750 +/- 250 mPa*s

### Areas of Application

The following table provides an overview of the glue's bonding on different materials:

MATERIAL	BONDING
Crystal	+
Glass	+
Ceramics	+
Stone	+
Aluminium	+
Brass	+
Silver	+
Steel	+
PC	+
PS	+
PVC/ABS	o
PMMA	o

#### Bonding types

- + sufficient or excellent bonding can be reached
- o sufficient bonding is possible
- sufficient bonding is nearly impossible

### Mixing CG 610 (A+B) two-component glue

The **50 g cartridge** of CG 610 is designed in a way that the containing resin and hardener do not have to be mixed together by the user. Just attach a dispensing gun and the dispensing tip (delivered with the 50 g adhesive package) to the cartridge and start gluing.



When using glue of the **750 g box**, resin and hardener have to be mixed. First, weigh the two glue components at a ratio of 2 : 1 (resin : hardener). It is very important to keep an exact mixing ratio of the two components to achieve maximum adhesion. Mix then the two components well for at least one minute. Only a fully homogenous mixture leads to the desired results.



When a homogenous mixture is achieved, put the glue into a dispenser/syringe and attach a dispensing tip.

**Dosage**

The glue can be precisely dispensed via a variety of dosage systems. Dispensers with a vacuum connection prevent the glue from dripping and reduce the amount of cleaning needed. The correct amount of glue will additionally protect the foiling from external influences. Attention must be paid to the application and quantity of the glue.

**GLUE APPLICATION**

**Irrespective of the shape of the gluing area**, the glue should be applied as follows:

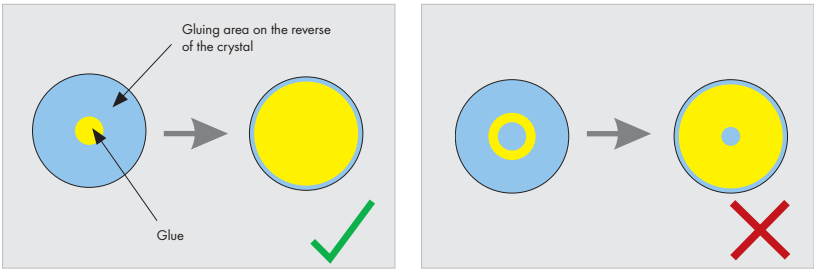

With a **round** gluing area, a dot of glue in the centre is sufficient. When the crystal is applied, the glue will be evenly distributed in the gluing gap. To glue a single spot, aim the dispensing needle just above the spot to be glued and lift it slowly upward to avoid any glue spreading out sideways.

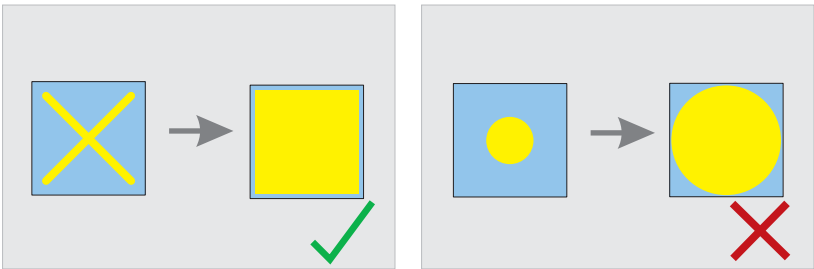

With a **square or rectangular** gluing area, apply a cross of glue to ensure it is evenly spread into the corners.

**GLUE QUANTITY**

When selecting the amount of glue to dispense, ensure that when setting and pressing down on the crystal, the glue spreads to the edges, thus offering additional protection for the foiling.

**Round Stone**

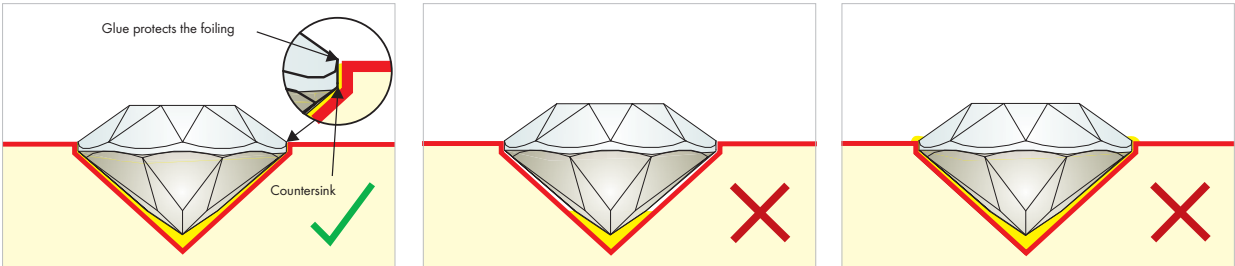

Too little glue

Too much glue

## Fancy Stone

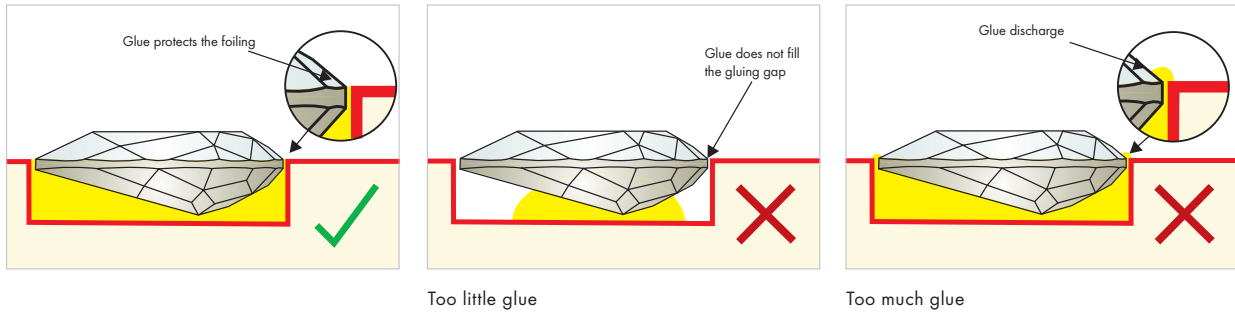

## Half Hole Pendants

Two different types of adhesive can be used to affix the single Half Hole Pendant to the metal cap: UV glue and two-component epoxy resin glue.

If using UV glue, the crystal must be permeable to UV light. This applies for the following Half Hole Pendant colors and effects: Crystal, Crystal AB, and Amethyst. Best results in internal tests were achieved using the UV glue DELO-PHOTOBOND GB 368.

Please note that some crystal colors absorb UV light and are thus unsuitable for use with UV glues: Siam, Smoky Quartz, and Jet. In this case using epoxy resin glue is suggested. In internal tests, the best bond was achieved using CG 500 (A+B).

As colors and effects not explicitly mentioned may provide variable results, in these cases it is recommended to perform application tests with UV glue or to choose the option of gluing with epoxy resin glue. For further information about commonly known and globally available glues and their adhesion on metal, please consult the Application Manual on our business website [SWAROVSKI.COM/PROFESSIONAL](http://SWAROVSKI.COM/PROFESSIONAL).



1 To achieve precise and consistent results, it is suggested to use a dosage system. Choose a dispensing tip with a diameter smaller than 1 mm and put a dot of glue into the pendant's hole. The amount of glue used depends on the type of adhesive and its curing behavior; performing application tests is therefore recommended.

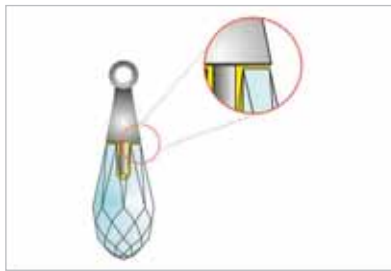

2 After setting the metal cap into the hole, the glue should be evenly distributed in the gluing gap and spread over the edges to also affix the metal part on top of the crystal. Remove excess glue before it is hardening, e.g. with a cotton wipe soaked in isopropyl alcohol.



## Setting

Once the glue has been dispensed the Swarovski product can be positioned. Pick up the crystals, for example with a wax stick or tweezers, apply them to the gluing position, and press down gently.

For preparing **Chatons** for the positioning process, a **Chaton Sieve** can be helpful. Take the black sieve (for size PP 0 - PP 1, art. 9030/003), the gray sieve (for size PP 2 – PP 20, art. 9030/001) or the blue sieve (for size PP 21 – SS 34, art. 9030/002) according to the Chatons' sizes. As each sieve provides two sides with different cavity sizes, make sure to choose the sieve type and side that perfectly matches the Chatons to be set. Place some crystals onto the sieve. By slightly shaking the tool and wiping over it with glove-covered fingers, the majority of Chatons automatically turn into the suitable position for gluing (table pointing upwards).



**Chaton Sieve** for Chatons size PP 0 – PP 1  
(art. 9030/003)



**Chaton Sieve** for Chatons size PP 2 – PP 20  
(art. 9030/001)



**Chaton Sieve** for Chatons size PP 21 – SS 34  
(art. 9030/002)

As a next step the Chatons can easily be picked up from the Chaton Sieve using a tool like the wax stick, tweezers, or a vacuum pick-up system. The use of a silicone wax stick is not recommended as this can impair the adhesion and the brilliance of the crystals.

Apply the crystals to the gluing position and press down gently. When working with cavities with large gluing gaps, the following aids assist in ensuring the optimum positioning:



A cross (or a similar tool) prevents the crystal from tipping over. Press the crystal down flat on the material using the chosen tool.

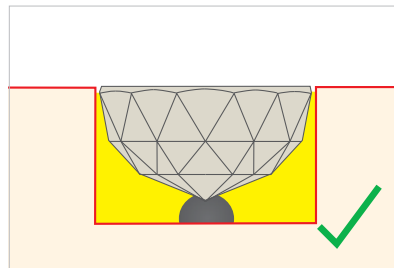

To prevent the crystal from sinking or tipping during the hardening process, a small **plasticine ball** can be used to fix it in place.

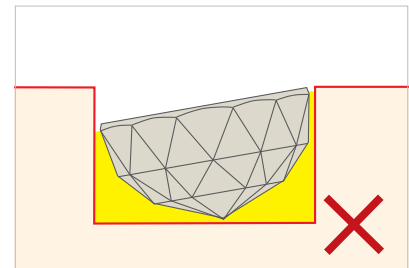

### Post-cleaning

Excess glue that escapes during setting can be carefully removed using a cotton wipe that has been soaked in a solvent, e.g. isopropyl alcohol. It must be removed **while the glue is hardening**, as dried glue cannot be fully removed. Remember to follow the glue manufacturer's instructions, as well as considering the resistance of the base material. **?!**

### Curing

The curing time of the glue depends mainly on the **temperature**, or on the **humidity** in the case of silicone glues. Please note the glue manufacturer's instructions.

To minimize shrinking and tension during hardening, we recommend a **maximum curing temperature of 50 °C (122 °F)**, with the exception of two-component epoxy resin glue CG 500 (A+B).

CG 500 (A+B) can be cured at a maximum temperature of **100 °C (212 °F)**, without any changes to its properties. **?!**

## OVERVIEW OF THE APPLICATION PROCESSES



1 The surface must be correctly pre-treated before gluing (e.g. cleaning, degreasing, sanding).



2 The glue should be applied with a dispenser.



3 Pick up the crystal, e.g. with the wax stick.



4 Carefully place the crystal in the cavity and press it down gently; post-clean and cure.

## PRODUCT-SPECIFIC APPLICATION INSTRUCTIONS

### Applying UV-transparent materials

When using UV glue, **at least one part** of the materials must be translucent for **UV light**. On a metal surface for example, only crystals without foiling can be applied. Similarly, foiled crystals can only be glued to UV-transparent materials. Please note that some crystal and glass colors as well as UV-stabilized plastics absorb UV light and are thus unsuitable for UV glues.



1 The surfaces to be glued must be properly pre-treated to achieve a sufficient surface tension. This can be tested via a Test Pen (art. 9030/000).



2 Dispense the UV glue.



3 Press down on the crystal, until the glue completely covers the gluing area.

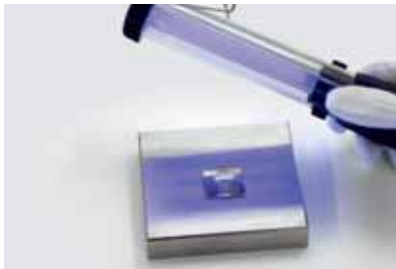

4 Cure the glue for a few seconds using a UV light (following the manufacturer's instructions), and remove any excess glue using a cleaning agent. The curing process can then be continued, according to the manufacturer's instructions.

**Note:** It is recommended that UV-protective eyewear is worn during curing, to prevent injury. Please follow the manufacturer's instructions.

## Applying Synthetics Hotfix on solid surfaces (with external glue)



1 The surfaces to be glued must be properly pre-treated, so as to achieve sufficient surface tension.



2 Apply the correct amount of glue onto the carrier material.



3 Elapse the glue equally on the material.



4 Position the motif in the desired location and press down firmly for a few minutes.



5 Glue that escapes during positioning can be carefully removed using a cotton wipe.



6 During curing it is suggested to put some weight on the motif.

## Applying Self-adhesive Elements

### APPLYING CRYSTAL TATTOOS

Crystal Tattoos are coated with a **dermatologically tested** glue that poses no threat to health and can therefore be applied directly to the skin.



1 Clean the skin with soap.



2 Peel off the white protective film at an acute angle.



3 Position the motif in the desired location and press down firmly for around 10 seconds.



4 Carefully remove the transparent film at an acute angle and press down on the motif again.

**Note:** Please read the additional instructions on working with Crystal Tattoos at the end of this manual.

## APPLYING CRYSTAL-IT



1 Press the crystals onto the transparent film.



2 Peel off the white protective film at an acute angle.



3 Position the motif in the location desired and press down firmly for around 10 seconds.



4 Carefully remove the transparent film at an acute angle and press down on the motif again.

## Applying other Self-adhesive Elements

### DRY APPLICATION



1 The surfaces to be glued must be properly pre-treated, so as to achieve sufficient surface tension.



2 Press the motif onto the transparent film.



3 Peel off the white protective film at an acute angle.



4 Position the motif in the location desired and press down firmly for around 10 seconds.



5 Carefully remove the transparent film at an acute angle and press down on the motif again.

**Note:** Prevent the self-adhesive back from sticking together, as separating it can cause damage. The minimum application temperature is 18 °C (64 °F), with the glue fully hardening after 72 hours.

For applications on surfaces subject to high mechanical stresses, it is recommended that a cavity is produced.

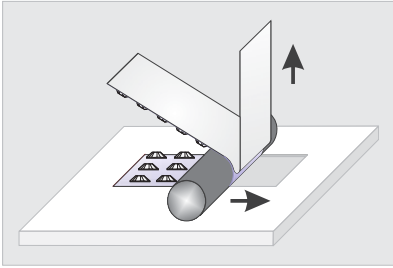

When applying Synthetics-it and Chatons, remove the white protective film during application in the pre-produced cavity.

When producing cavities, the dimensions should consider the tolerance of the product and the production tolerance. The tolerances of the product can be requested from your Swarovski representative.



### WET APPLICATION

For larger motifs and those that must be positioned accurately on surfaces, a wet application is recommended. It is essential, however, that the base does not absorb the soap water that is used here.



1 Moisten the cleaned surface with soap water.



2 Carefully peel off the white protective film at an acute angle, and carefully position the product on the wet surface. After positioning it, press down on the soap water beneath the motif, e.g. using a rubber roller.



3 Carefully remove the transparent film at an acute angle and leave the surface to dry.



4 After drying, press down firmly on the motif again, e.g. using a rubber roller.

## Applying Flat Backs No Hotfix for mosaic tiles

Due to their dimensions (outer dimensions and height) and coating (protective lacquer), selected Flat Backs No Hotfix have been tailored specially for use in tiles and mosaics.

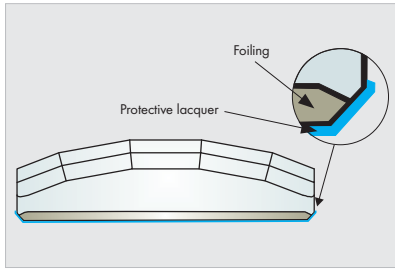

Protective lacquer is applied to the foiling of all crystals, and fully covers the reflective surface. Protective lacquer prevents moisture, cleaning agents, etc. from coming into direct contact with the reflective layer, which can lead to corrosion and damage the crystal.

Long-term, satisfactory solutions can only be achieved with **paper-glued** mosaic tiles and the use of recommended tile glues and joint sealers. When working with **net-glued** mosaics, their absorption and storage of moisture means the **support net** must be **completely removed** in the areas where the crystals are to be applied.

Find suppliers for tile glues and joint sealers on the supplier list on page 43. Solvent-resistant and alkaline tile glues and joint sealers are not recommended.

### UNSUITABLE AREAS OF APPLICATION

- In swimming baths and steam rooms
- In contact with chlorine and other aggressive cleaning agents
- In saunas, due to the high temperatures and moisture
- Outside

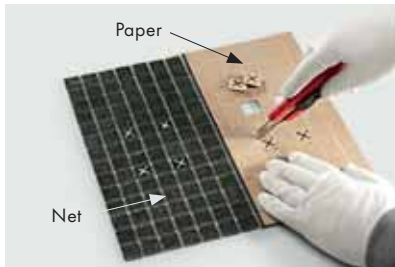

1 Cut out the marked tile area and remove it from the mosaic.



2 Apply the tile glue to the prepared base according to the manufacturer's instructions, then carefully position the mosaic tile and press down.

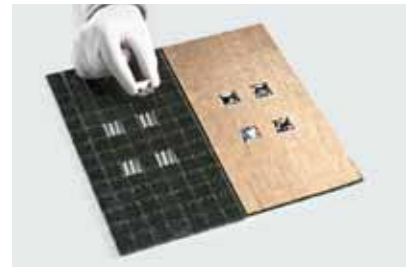

3 Place the individual crystals in the gaps and lightly press down.



4 Before curing, remove any excess glue with a damp sponge; follow the manufacturer's information regarding curing.



5 After curing, remove the paper support. Following this, the mosaic can be grouted with a soft rubber scraper.



6 Excess joint sealer can be removed with a wet sponge during curing.

**Note:** Please be aware that many tile glues and joint sealers can contain abrasive materials, which can lead to scratching of the crystal. To avoid damaging the crystal, these parts should be carefully cleaned with mild, pH-neutral cleaning agents and cleaning sponges.

## USEFUL INFORMATION

### Applications on silver jewelry

Without protection, silver jewelry can turn yellow or black with time due to chemical reactions. To slow or stop these reactions the surface of silver jewelry is often covered with a temporary (wax-based) or permanent protective coat (varnish-based). Tarnishing on the surface of the metal often results in a decline in the surface tension under the recommended 38 mN/m.

TARNISHING PREVENTION SYSTEMS	
<b>Temporary protection against tarnishing:</b>	<b>Permanent protection against tarnishing:</b>
▪ Wax-based	▪ Varnish-based
▪ Low surface tension	▪ Surface tension depends on varnish
<b>Recommendation:</b> Protect the rest of the piece after gluing	<b>Recommendation:</b> Use a tarnishing protection system with sufficient surface tension

### Protective film

A self-adhesive film can protect against dirt during the application process and aid in positioning.

#### BLIND HOLE



1 To protect the surface of the material used (e.g. metal, tiles, etc.) from dirt, a self-adhesive film can be applied.



2 It is then cut out along the previously produced cavities.



3 The crystal can now be glued into the cavity. Once any excess glue has been removed, the adhesive film can be removed following curing.



## END-TO-END CAVITIES



1 Apply a self-adhesive film to the **front** of the material.



2 Place the Flat Backs No Hotfix elements into the end-to-end cavity from the **back**.

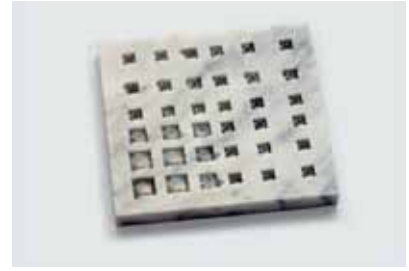

3 Now fill the cavity with glue. The glue should cover the entire foiling of the crystal, so as to avoid corrosion. The self-adhesive film **prevents the glue spreading** onto the front.



4 Once the glue has cured, the film can be removed.

**Note:** Highly viscous glues are best suited for end-to-end cavities, as they do not spread through the cracks at the front.

## Cutting and gluing Crystal Mesh

The transparent film should not be removed before gluing. The film allows the individual crystals to be aligned perfectly, and provides Crystal Mesh with the stability necessary for flawless application.

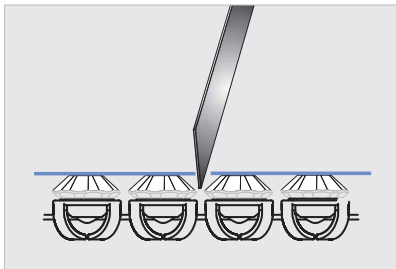

Cut the transparent film between the rows of crystals with a Stanley knife, though do not pull it away – otherwise the stability of the crystals will be lost.

When gluing flexible Crystal Mesh products, do not remove the transparent film until the glue has cured to ensure the proper alignment of the mesh.

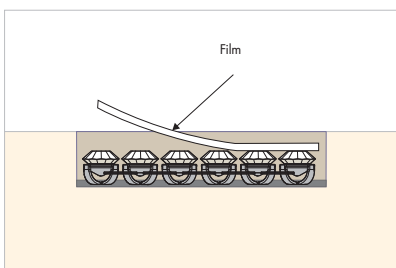

### Cutting Crystaltex Chaton Bandings and Cabochon Bandings

When working with Crystaltex Chaton Bandings and Cabochon Bandings, the lack of space between crystals means great care must be taken during cutting, so as to avoid damaging the crystal.

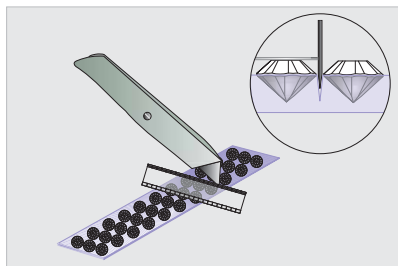

1 Cut into the support film between the crystal rows with a Stanley knife.

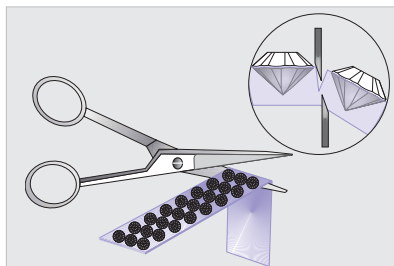

2 Snap and cut off the Crystaltex Chaton Banding and Cabochon Banding along the scored edge.

### Applications on plastics

There are many types of synthetic materials. The following table contains information regarding the adhesive qualities of a selection of plastics.



PLASTICS	USUAL COMMERCIAL NAME	ADHESIVE QUALITIES
ABS	Abselex, Lacqran, Tynrene	good
ASA	Luran S, Geloy	good
CA	Ultraplan, Saxetat, Thodialite	good
EP	Araldite, Ferropox, Duroxyn	good
PA	Degamid, Nylon, Perlon	very difficult
PC	Polycarbafil, Lexan, Andoran	good
PE	Geberit, Hostalen G, Ferrozell	difficult
PET	Cardura, Atlas, Eralyt	difficult
PF	Formanyl, Holoplast, Kerit	good
PIB	Parapol, Oppanol, Vistanex	good
PMMA	Plexiglass, Resartglass	good
POM	Delrin, Kematal, Ertacetal	difficult
PP	Moplefan, Proplex, Verelite	difficult
PS	Hostyrene, Styropor, Noblen	good
PTFE	Teflon®, Gafflon, Ferrotron	very difficult
PVC	Marcoproplat, Ravinil, Sumilit	good
SAN	Litac, Tuf-Flex, Vestoran	good
SILICONE	Silopren, Contiduct, Corotex	difficult
UP	Celipal, Sirester, Vestopal	good

## QUICK ASSISTANCE

The following table outlines common problems and causes when gluing Swarovski crystals, and offers advice on how to avoid them. Further details and more extensive descriptions can be found in the section marked with a **?!?**

PROBLEM	CAUSE
<b>The crystal has become discolored:</b>	
The crystal is matt or yellowed.	1, 2
The crystal seems black and dull compared to the surrounding crystals.	3
The crystal has been plated.	4
<b>The crystal has detached from the cavity without the foiling:</b>	
The crystal has become discolored.	5, 6
The crystal has detached with the mirror coating but without the platinum foiling or the glue.	7, 8, 9
<b>The crystal has detached from the cavity with the foiling:</b>	
Glue is attached to the crystal.	10, 11, 12, 13, 14
No glue is attached to the crystal anymore.	15, 16, 17
<b>Excess glue:</b>	
Before hardening.	2
After hardening.	18

CAUSE	RECOMMENDATION
1 Glue residues have not been completely removed and have been smeared over the crystal.	Use a suitable dispenser to apply exactly the right amount of glue. Dispensers with a vacuum connection prevent the glue from dripping and reduce the amount of cleaning needed.
2 Too much glue was used.	Be sure to use the exact recommended dosage and to carefully remove any excess glue, e.g. using acetone or isopropyl alcohol.
3 The axis of the cavity was already off-center in the original model or the cavity was not drilled straight in the unfinished casting.	Use a special bit when drilling the original model. This offers more precise control of the direction and depth of the drilling.
4 The jewelry was only plated after the crystals had been glued to it.	It is recommended to complete the plating before gluing the crystals.
5 A gluing gap that has not been completely filled is causing corrosion.	Make sure the exact dosage of glue is used.
6 Tensile stresses are reducing the adhesion of the mirror coating. Oxygen is penetrating between the stones and the mirroring and causing oxidization.	Use glue that is more elastic and that does not shrink as much.
7 An incorrect glue system was used.	Carry out tests with other glue systems.
8 Incorrect proportions of resin and hardener were used.	Follow the glue manufacturer's mixing instructions.
9 Cleaning agents have affected the glue and/or the protective coating.	Use less solvent or a different type of solvent.
10 Residues of polishing agent were not completely removed before plating.	Double check the type of cleaning process used.
11 A varnished piece of jewelry has not been correctly pre-treated before gluing.	Improve the adhesion of the glue, e.g. with low-pressure plasma treatment or flame treatment if necessary.
12 Too little glue was used.	Make sure the exact dosage of glue is used.
13 The cavity has the wrong shape after plating.	Re-work the original model to improve the cavity shape.
14 Electrolyte residues have not been completely removed.	Double check the type of cleaning process used.

CAUSE		RECOMMENDATION
15	The specified processing time was exceeded and as a result the glue has already hardened.	Reduce the processing time.
16	Too little glue was used.	Make sure the exact dosage of glue is used.
17	General glue problems.	Follow the manufacturer's instructions. Check the conditions under which the glue is stored. Excess solvent could have corroded the glue and/or the foiling.
18	The jewelry piece was put under stress before the glue had hardened.	Make sure the glue has hardened, for example before transporting the jewelry.





# CERALUN

Ceralun is a high-performance, two-component ceramic epoxy composite especially developed for the application of Swarovski products.

## PRODUCT OVERVIEW

The following products are suitable for application with Ceralun:

	CERALUN
Round Stones	✓
Fancy Stones	✓
Flat Backs No Hotfix	✓

Ceralun is a versatile and strong two-component, high-performance ceramic epoxy composite. This clay has been specifically developed and tailored to embed foiled and unfoiled crystals. It is an absolutely essential material for innovative design. Ceralun has a high level of hardness, rigidity, and shock absorbance. It is resistant to sweat, humidity, or climatic changes, and shows no aging.

### Available Basic Colors



White SP

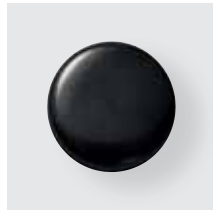

Black



Rose SP

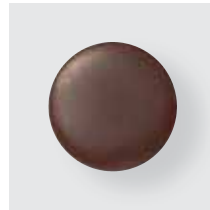

Walnut



Dark Sapphire



Malachite



Red



Yellow

### Available Shining Colors



Gold



Silver

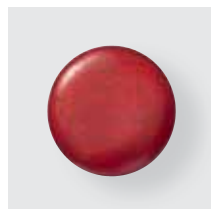

Shining Red

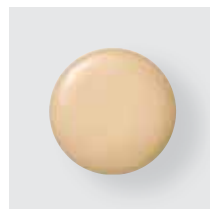

Pearl Silk



Anthrazite



Shining Green



Shining Lilac



## MACHINES, TOOLS, AND AIDS

The following machines, tools, and aids can be used for the various processes involved in the application of Swarovski products with Ceralun:



**Test Pen** (art. 9030/000)



**Isopropyl alcohol/Acetone**



**Blow torch**



**Corona**



**Plasma cleaner**



**Precision balance**



**Gloves**



**Protective eyewear**



**Ceralun (A + B)**  
Two-component ceramic epoxy composite  
(5 x 20 g)



**Ceralun (A + B)**  
Two-component ceramic epoxy composite  
(100 g)



**Ceralun (A + B)**  
Two-component ceramic epoxy composite  
(10 x 100 g)



**Ceralun (A + B)**  
Two-component ceramic epoxy composite  
(1 kg)



**Release Agent**  
Contains high molecular liquid wax (100 ml)



**Vacuum pick-up system**

Courtesy of I&J Fisnar Inc.



**Chaton Sieve** for Chatons size PP 0 - PP 1  
(art. 9030/003)

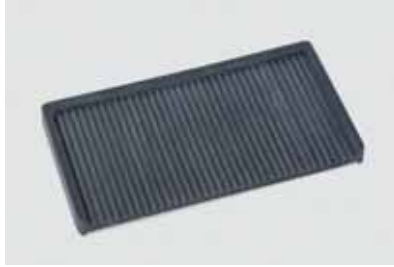

**Chaton Sieve** for Chatons size PP 2 - PP 20  
(art. 9030/001)



**Chaton Sieve** for Chatons size PP 21 - SS 34  
(art. 9030/002)



**Tweezers**



**Wax stick**



**Drying oven**



**Freezer**

Fotografia: istockphoto.com

## SUPPLIERS

This list provides an overview of selected suppliers worldwide.

MACHINES / TOOLS / AIDS	SUPPLIER	CONTACT
Test Pen	Swarovski: art. 9030/000	<a href="http://www.swarovski.com/professional">www.swarovski.com/professional</a>
Ceralun Basic Colors	Swarovski: art. 9020, 5 x 20 g, America, Asia, Europe art. 9020, 100 g, America, Asia, Europe art. 9020, 10 x 100 g, America, Asia, Europe art. 9020, 1 kg, America, Asia, Europe  Black (A+B), Dark Sapphire (A+B), Malachite (A+B), Red (A+B), Rose (A+B), Walnut (A+B), White (A+B), Yellow (A+B)	<a href="http://www.swarovski.com/professional">www.swarovski.com/professional</a>
Ceralun Shining Colors	Swarovski: art. 9020, 5 x 20 g, America, Asia, Europe art. 9020, 100 g, America, Asia, Europe art. 9020, 10 x 100 g, America, Asia, Europe art. 9020, 1 kg, America, Asia, Europe  Anthracite (A+B), Gold (A+B), Pearl Silk (A+B), Shining Green (A+B), Shining Lilac (A+B), Shining Red (A+B), Silver (A+B)	<a href="http://www.swarovski.com/professional">www.swarovski.com/professional</a>
Ceralun Release Agent (100 ml)	Swarovski: art. 9020, America, Asia, Europe	<a href="http://www.swarovski.com/professional">www.swarovski.com/professional</a>
Vacuum pick-up system	I & J Fisnar, Inc.  Epoxy & Equipment Technology PTE., Ltd.  Hottemp (M) Sdn. Bhd.  PT. SKT International	<a href="http://www.fisnar.com">www.fisnar.com</a>  <a href="http://www.eetdispensing.com">www.eetdispensing.com</a>  <a href="http://www.hottemp.com.my">www.hottemp.com.my</a>  <a href="http://www.sktisolution.com">www.sktisolution.com</a>
Chaton Sieve	Swarovski:  For Chaton size PP 0 – PP 1: art. 9030/003  For Chatons size PP 2 – PP 20: art. 9030/001  For Chatons size PP 21 – SS 34: art. 9030/002	<a href="http://www.swarovski.com/professional">www.swarovski.com/professional</a>
Pick-up stick	Crystal Ninja	<a href="http://www.crystalkatana.com">www.crystalkatana.com</a>
Drying oven	Heraeus Holding GmbH  VWR International, LLC	<a href="http://www.heraeus.com">www.heraeus.com</a>  <a href="http://www.vwr.com">www.vwr.com</a>

---

## APPLICATION

When working with Ceralun, optimal results are obtained by coordinating the entire application process. Following the application steps in the right order is very important. Experience has shown that the most common reasons for crystals becoming detached are inappropriate areas of application, the wrong mixing ratio of the two components, or not mixing them together long enough until a homogenous appearance is achieved.

### Main advantages of Ceralun

- Specifically developed and tailored to embed foiled and unfoiled Swarovski crystals.
- High level of hardness, rigidity, and shock absorbance.
- Resistant to perspiration, humidity, or climatic changes and shows no aging.
- Allows new design possibilities.
- Perfect material to generate a large variety of surfaces and structures.
- Applicable on 3D-shaped surfaces.
- Alternative solution to gluing.

### Ceralun two-component ceramic epoxy composite

Ceralun was especially developed for the application of both foiled and unfoiled Swarovski crystals, exclusively distributed by Swarovski for professional use within the jewelry segment and other industries such as accessories, interiors, and electronics.

### Physical data

Mixing ratio (A : B)	1:1 (by weight)
Pot life at room temperature (23 °C/73.4 °F)	max. 3 h
Total hardening time at room temperature (23 °C/73.4 °F)	72 h
Time needed to harden in an oven at 40 °C/104 °F	12 h
Time needed to harden in an oven at 80 °C/176 °F	2 h
Time required before handling strength is reached at room temperature (23 °C/73.4 °F)	12 h
Humidity during curing	30 - 70%
Density	2.5 g/cm <sup>3</sup>
Hardness (according to DIN 53505)	D82

### Storage conditions

Storage time at room temperature (23 °C/73.4 °F, 55% rel. hum.)	12 months
Lowest storage temperature	2 °C/35.6 °F

Ceralun has optimal adhesive characteristics for applications on metal, glass, crystal, gluable plastic surfaces, rubber, wood, cork, and porcelain, unless the materials do not have the right surface tension.

### Checking the surface tension

The surface tension is an indicator for the wetting properties of the surface the Ceralun should be applied to. A surface tension of at least 38 mN/m is recommended for working with Ceralun. It should also be randomly tested during production. It is best to use the Test Pen (art. 9030/000) to measure the surface tension.



1 Mark the surface.



2 If the ink remains visible for 2 seconds, the surface is suitable for working with Ceralun.



3 If the ink disappears or forms bubbles, the surface is not suitable for applying Ceralun. In this case, the pre-treatment cleaning methods should be checked.

**Note:** On porous or absorbent materials, the surface tension cannot be checked with the Test Pen. If the Test Pen is used on highly polluted surfaces (e.g. grease, oil) or on material like wood, the Test Pen might be polluted as well and cannot be used anymore.

### Pre-treatment

If the surface tension is below 38 mN/m, the following pre-treatment cleaning methods, applied in the correct order, can be effective in reaching the right level.

TYPES OF CLEANING	PRE-TREATMENT CLEANING METHODS
<p><b>1 Mechanical cleaning</b></p> <p>This involves sanding, blasting, or brushing but is not usually necessary for jewelry.</p>	<ul style="list-style-type: none"> <li>▪ Removal of dirt, residues of varnish, rust and/or scale</li> <li>▪ Roughening the surface</li> </ul>
<p><b>2 Washing and degreasing</b></p> <p>Here it is important to ascertain that the tensides contain no silicone, as this would impair adhesion. When using solvents it is advisable to test the durability of the surface to be cleaned beforehand to avoid any damage. <b>Solvents containing substances with a high boiling point should not be used</b> due to the high risk of residue. If using cleaning agents, wait a few minutes to allow them to evaporate.</p>	<ul style="list-style-type: none"> <li>▪ Cleaning with tenside solutions, rinsing with de-ionized water</li> <li>▪ Cleaning with isopropyl alcohol/ethanol</li> <li>▪ Cleaning with acetone (MEK/ethyl acetate)</li> <li>▪ Cleaning with a cleaning solvent: should not contain high boiling point substances (risk of residue)</li> </ul>
<p><b>3 Physical cleaning and activation</b></p> <p>These cleaning methods can be applied if mechanical cleaning or washing and degreasing are either not possible or have not resulted in a surface tension of &gt;38 mN/m. Therefore the pre-treatment cleaning method used should be done on a case-by-case basis.</p>	<ul style="list-style-type: none"> <li>▪ <b>Flame treatment with a blow torch</b> The surface to be treated is exposed to the flame of a torch very briefly. When using special gas mixtures, surface silication can also be carried out, so as to apply a more adhesive coating.</li> <li>▪ <b>Corona treatment</b> An electric corona discharge is briefly applied to the surface.</li> <li>▪ <b>Plasma treatment</b> Plasma treatment offers precise cleaning and activates the surface via an ionized gas.</li> </ul>
<p><b>4 Chemical cleaning and primers</b></p> <p>Applying a primer improves adhesion and helps to prevent corrosion.</p>	<ul style="list-style-type: none"> <li>▪ Applying small amounts of solvent and activating the surface.</li> <li>▪ Applying a primer.</li> </ul>

Please pay high attention to not deviate from the recommended mixing ratio of 1:1 of the components (resin and hardener) and to mix the two components until a homogenous appearance is achieved.

### Mixing Ceralun two-component ceramic epoxy composite



1 Cut off resin and hardener with a knife.



2 Weigh the two components. The mixing ratio for Ceralun is 1 : 1 by weight.



2 Mix resin and hardener until a homogenous appearance is achieved.

### Proper setting of crystals

After mixing the two components together, the crystals can be set. To prepare Chatons for the positioning process, a **Chaton Sieve** can be helpful. Take the black sieve (for size PP 0 – PP 1, art. 9030/003), the gray sieve (for size PP 2 – PP 20, art. 9030/001) or the blue sieve (for size PP 21 – SS 34, art. 9030/002) according to the Chatons' size. Place some Chatons onto the sieve. By slightly shaking the tool and wiping over the crystals with glove-covered fingers, the majority of Chatons automatically get turned into the suitable position for gluing (table pointing upwards).



Using a Chaton Sieve can facilitate the setting of Chatons

As a next step the Chatons can easily be picked up from the sieve using a tool like the wax stick, tweezers, or a vacuum pick-up system. The use of a silicone wax stick is not recommended as this can impair the adhesion and the brilliance of the crystals. Apply the Chatons to the desired position and press down gently.

We recommend a maximum working time of three hours at a temperature of 23 °C/73.4 °F to set the Swarovski products. It is not possible to set crystals at room temperature after a period of three hours because the required level of adhesion can no longer be achieved.

Please take care that the pavilion of the crystal is surrounded by Ceralun right up to the level of the stone's girdle. It is not necessary to leave any particular space between the crystals when setting them.

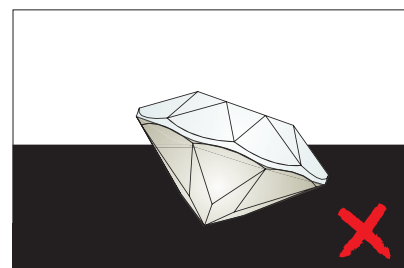
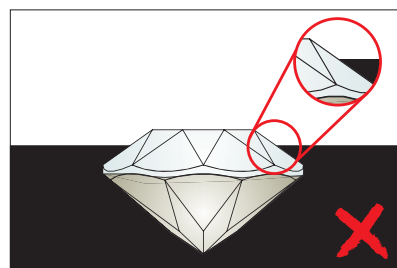
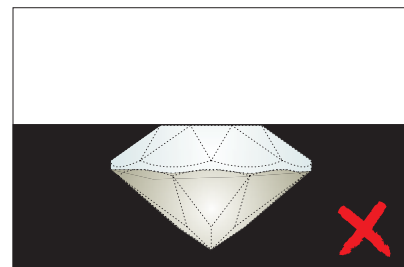
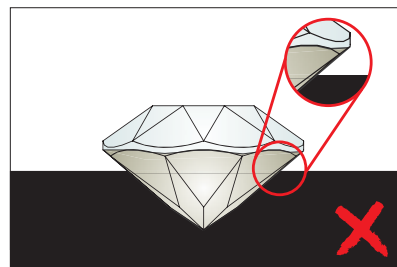
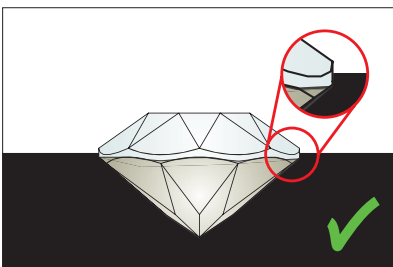

### Different processing methods

Ceralun is the perfect material for generating a variety of surfaces and structures. Possible ways of processing are the forming method and the stamping technique.

#### FREE FORMING



1 Place and press the clay onto the relevant area. Be careful not to trap air between Ceralun and the base material.



2 Mold the surface into the required shape and smooth the surface with the recommended Release Agent.



3 Pick up the crystal with a vacuum pick-up system – or with a pair of tweezers or a wax stick. Carefully place the crystal and press it down gently.

#### GENERATING SHINY SURFACES WITH THE FREE FORMING METHOD

When a piece of jewelry is created where parts of Ceralun are visible, a smooth and shiny clay surface might be desired. In order to create a shiny surface, gently wipe and polish the clay with your silicone glove-covered finger using the recommended Release Agent or some water drops. The Ceralun surface can be polished up to 2 hours after the crystals have been set.

#### STAMPING TECHNIQUE

The stamping technique is suitable to produce structured surfaces.



1 Pre-treat the pattern cautiously with the recommended Release Agent.



2 Gently press the pattern onto the surface.



3 After removing the pattern from the clay, the crystals can be set.

#### GENERATING SHINY SURFACES WITH THE STAMPING TECHNIQUE

If a larger surface of shiny Ceralun is needed, the following aids are required: transfer foil, a pasta machine or rolling pin, and a freezer. Knead the clay and put it between two layers of foil. Smoothen it with the help of a pasta machine or with a rolling pin. Using the pasta machine is the recommended option, as a consistent height of the Ceralun is achieved easier than with the rolling pin. When the clay inside the foil is as flat as desired, put it into the freezer for approx. 15 minutes. The cold reduces the bonding between Ceralun and foil, so that the foil can easily be detached from the flat and shiny clay.

### 3D SILICONE MOLDS

The work and cost saving method of using 3D silicone molds is recommended for larger production units. A 3D silicone mold is produced based on a master model. This can be re-used for several times.



1 First press the Ceralun into the 3D silicone mold to form the required shape.



2 Any overlapping material can be trimmed off with a knife.

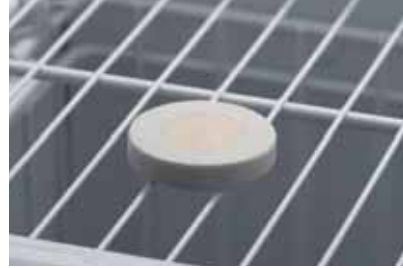

3 In order to make it easier for you to remove the Ceralun from the mold, it should first be stored in the freezer. The length of time the filled mold should remain in the freezer depends on the thickness and amount of the Ceralun used.



4 After taking the mold out of the freezer, the Ceralun can be removed from it and gently pressed into place on the chosen object.



5 Please be sure to remove any condensed water.



6 Once the Ceralun reaches a lukewarm temperature, you can proceed with setting the crystals.

CHECKING SURFACE TENSION  
AND PRE-TREATMENT

DOSAGE, MIXTURE  
AND SETTING

PROCESSING  
METHODS

CURING

The hardening time and final adhesion strength of Ceralun are dependent on the temperature. The total hardening time at room temperature of 23 °C (73.4 °F) takes 72 hours. This can be accelerated using heat of max. 80 °C (176 °F).



## USEFUL INFORMATION

### Extension of pot life



1 Store already mixed Ceralun in a freezer to extend the pot life. Ceralun can be stored in a freezer for up to 24 hours at a temperature of around - 20 °C (- 4 °F).



2 This makes it possible to interrupt the setting process and continue again later without losing the adhesion force.



3 It is necessary to gently remove any condensed water that occurs during the defrosting process.

## MIXING DIFFERENT COLORS OF CERALUN

You can mix different colors together as you wish. Please consider that you have to separately mix the epoxy resin and hardener of each color before you mix them together. Below you find some examples of mixed colors and the corresponding mixing ratio.



Based on Black SP

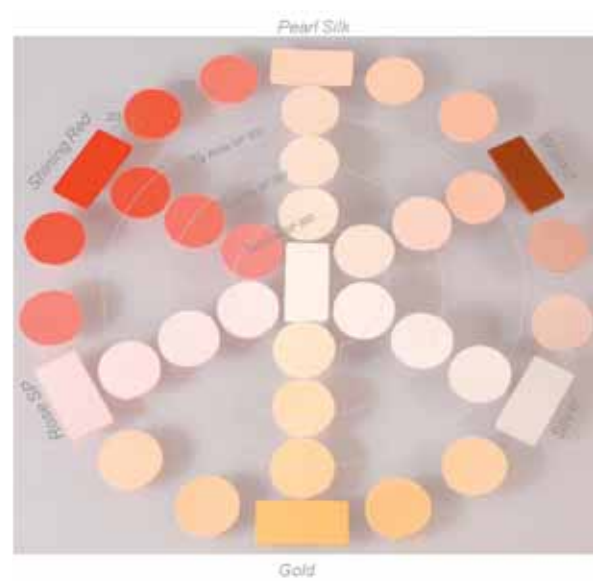

Based on White SP 300

## QUICK ASSISTANCE

PROBLEM	CAUSE
Ceralun does not cure.	1, 2, 6
Ceralun is not bonding with the base material.	1, 2, 3, 6
Crystals fall off.	1, 2, 4, 5, 6
Ceralun cannot be removed from the silicone mold.	7, 8
Using the stamping technique, Ceralun cannot be removed from the surface pattern.	7
Ceralun appears foggy/cloudy after curing.	5, 6, 7

CAUSE	RECOMMENDATION
<b>1</b> An error has occurred during the calculation of the right mixing ratio between the two components (resin/hardener).	Do not deviate from the recommended mixing ratio of the components (resin/hardener), 1 : 1.
<b>2</b> Resin and hardener have not been mixed until a homogenous appearance was achieved.	Be sure to use the exact recommended dosage and to carefully remove any excess Ceralun, e.g. using acetone or isopropyl alcohol.
<b>3</b> The base material is not suitable for using Ceralun or it has been incorrectly pre-cleaned.	Check the surface tension. If the surface tension is below 38 mN/m, carry out pre-treatment cleaning methods.
<b>4</b> The specified processing time was exceeded and as a result Ceralun has already hardened.	Reduce the processing time to a maximum of two hours at a temperature of 23 °C (73.4 °F)
<b>5</b> If stored in the freezer, condensed water can occur during the defrosting process.	Take care to gently remove any condensed water that occurs during the defrosting process.
<b>6</b> Ceralun has been stored for too much time in the freezer.	Make sure not to exceed the recommended time of 24 hours when Ceralun is stored in a freezer at a temperature of around - 20 °C (- 4 °F).
<b>7</b> No or not enough Release Agent has been used.	The Release Agent is a useful aid to be able to remove Ceralun from any surface. Carefully dose the used amount of Release Agent.
<b>8</b> Ceralun has not been stored in a freezer or has been stored for too little time.	Storing Ceralun in a freezer makes it easier for you to remove it from the mold.





## **HOTFIX** APPLICATION

The Swarovski product assortment includes a wide range of Hotfix products. These can be applied simply, quickly and securely. Hotfix technology is ideal for application in the fields of textiles, interior décor and accessories.

---

## PRODUCT OVERVIEW

The following products are suitable for Hotfix application:

HOTFIX APPLICATION
Flat Backs Hotfix
Transfers
Synthetics Hotfix
Crystal Mesh

---

## MACHINES, TOOLS, AND AIDS

The following machines, tools, and aids are used in the Hotfix application of Swarovski crystals:



Heat press



Double heat press



Continuous fusing press



Ultrasonic device



Stone setting machine



Applicator



Iron

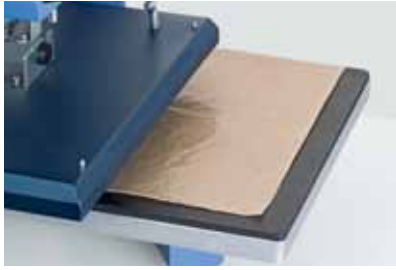

**Teflon®**  
(art. 9010/003)

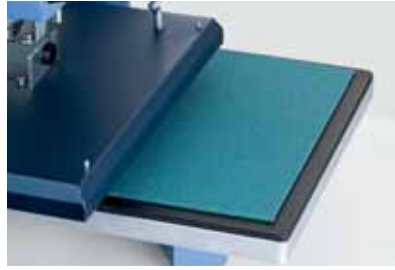

**Silicone ironing pad (foam)**  
(art. 9010/002)

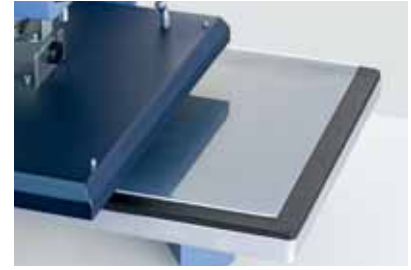

**Silicone pad (aid for Diamond Transfers)**  
(art. 9010/005)



**Felt**



**Standard cardboard**



**Standard pressing cloth**



**Temperature measuring strips**  
(art. 9010/007)



**Laser temperature measuring device**



**Transfer film**



**Silicone board**  
(art. 9010/006)

## SUPPLIERS

This list provides an overview of selected suppliers worldwide.

MACHINES / TOOLS / AIDS	SUPPLIER	CONTACT
Heat press	Bestblanks	<a href="http://www.bestblanks.com">www.bestblanks.com</a>
	Elna SMP Singapore	<a href="http://www.elnasingapore.com">www.elnasingapore.com</a>
	Fukutomi Equipment & Supplies	<a href="http://www.fukutomidigital.com">www.fukutomidigital.com</a>
	Hix Corporation	<a href="http://www.hixcorp.com">www.hixcorp.com</a>
	Zhejiang Huangyan Garment Machinery Factory	<a href="http://www.ji-feng.com">www.ji-feng.com</a>
	Jesse J. Heap & Son, Inc.	<a href="http://www.jesseheap.com">www.jesseheap.com</a>
	Nagel & Hermann	<a href="http://www.strass.cc">www.strass.cc</a>
	OSHIMAKK Co., Ltd.	<a href="http://www.oshima.com.tw">www.oshima.com.tw</a>
	Pro World	<a href="http://www.proworldinc.com">www.proworldinc.com</a>
	ColDesi, Inc	<a href="http://www.rhinestonecamsmachines.com">www.rhinestonecamsmachines.com</a>
	RPL Supplies, Inc.	<a href="http://www.rplsupplies.com">www.rplsupplies.com</a>
	STAHL'S Europe GmbH	<a href="http://www.stahls.de">www.stahls.de</a>
	Teva	<a href="http://www.teva-organisation.com">www.teva-organisation.com</a>
Thermopress Europe	<a href="http://www.thermopress.de">www.thermopress.de</a>	
Double heat press	Teva	<a href="http://www.teva-organisation.com">www.teva-organisation.com</a>
	Wagner GmbH	<a href="http://www.wagner-transferpressen.de">www.wagner-transferpressen.de</a>
Continuous fusing press	Maschinenfabrik Herbert Meyer GmbH	<a href="http://www.meyer-machines.com">www.meyer-machines.com</a>
Ultrasonic device	Ever Green Ultrasonic Co., Ltd.	<a href="http://www.evergreen-taiwan.com">www.evergreen-taiwan.com</a>
	Zhejiang Huangyan Garment Machinery Factory	<a href="http://www.ji-feng.com">www.ji-feng.com</a>
	Jesse J. Heap & Son, Inc.	<a href="http://www.jesseheap.com">www.jesseheap.com</a>
	Perfecta Schmid Triopan AG	<a href="http://www.perfecta.ch">www.perfecta.ch</a>
	Pessani s.r.l.	<a href="http://www.pessani.com">www.pessani.com</a>
	ColDesi, Inc	<a href="http://www.rhinestonecamsmachines.com">www.rhinestonecamsmachines.com</a>
	Shanghai Exing Industry Co., Ltd.	<a href="http://www.exingsh.com.cn">www.exingsh.com.cn</a>
Teva	<a href="http://www.teva-organisation.com">www.teva-organisation.com</a>	
Stone setting machine	Dairo Machine Co.	<a href="http://www.dairomc.com">www.dairomc.com</a>
	Nagel & Hermann	<a href="http://www.strass.cc">www.strass.cc</a>
	Pessani s.r.l.	<a href="http://www.pessani.com">www.pessani.com</a>



MACHINES / TOOLS / AIDS	SUPPLIER	CONTACT
Applicator	Creative Crystal® Company	www.bejeweler.com
	Donwei Machinery Industry Co., Ltd.	www.donwei.com.tw
	Dreamtime Creations	www.dreamtimecreations.com
	Hobbyring	www.hobbyring.de
	Kandi Corp.	www.kandicorp.com
	Shanghai Exing Industry Co., Ltd.	www.exingsh.com.cn
Teflon® (100 x 50 cm, 40 x 20 inches)	Swarovski: art. 9010/003	www.swarovski.com/professional
Silicone ironing pad (foam) (134 x 100 cm, 54 x 40 inches)	Swarovski: art. 9010/002	www.swarovski.com/professional
Silicone pad (aid for Diamond Transfers) (50 x 50 x 0.2 cm, 20 x 20 x 0.08 inches)	Swarovski: art. 9010/005	www.swarovski.com/professional
Temperature measuring strips	Swarovski: art. 9010/007	www.swarovski.com/professional
Silicone board (aid for designing Transfers) (50 x 25 x 0.1 cm, 20 x 10 x 0.05 inches)	Swarovski: art. 9010/006	www.swarovski.com/professional
Laser temperature measuring device	PCE Instruments	www.industrial-needs.com
Transfer film	DSO, Co., Ltd.	www.dso-co.com
	Nagel & Hermann	www.strass.cc

## APPLICATION

### Basic Hotfix Principles

Hotfix elements have a coating of hot-melt glue on the back, enabling swift, simple application. This glue is activated by **heat** (applied either directly or indirectly via ultrasound), and bonds with the carrier material. When cooling, the glue hardens and securely and permanently fixes the elements in place. The Swarovski Hotfix adhesive is characterized by its **wash resistance** and **easy-care** properties. The temperature, application time and pressure can be varied according to the carrier material.

Further details and information can be found in the "Care Instructions" chapter and in the Hotfix Selector table at the end of this chapter.

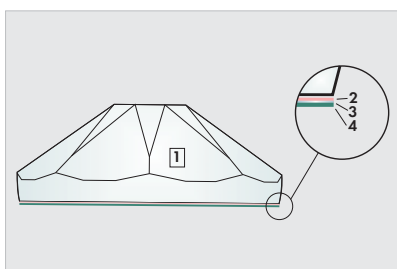

**1 Crystal**

**2 A – Foiling:**

A brilliant silver-based (Ag) mirror coating with a rose-colored protective layer

**3 Primer:**

Transparent primer improves the bonding between the Hotmelt adhesive and the A-Foiling

**4 Hotmelt adhesive:**

This transparent adhesive, developed by Swarovski, allows the application of the crystals on a variety of different materials

Before beginning the application process, you should always check whether the carrier material is suitable for Hotfix application. Please check the following criteria:

- Heat resistance (min. 120 °C/250 °F)
- Resistance against pressure
- Application area of the product
- Suitability of surface properties and absorbency

### Checking absorbency via the water drop test

The water drop test is a quick and easy way to get an initial idea of the absorbency of the carrier material. Apply a couple of water drops onto the carrier material. If the material quickly absorbs the drops, it offers good absorbency. If the water pearls off the carrier material, or if it takes a long time to be absorbed, the material offers insufficient absorbency. This can impair the effectiveness of Hotfix application.

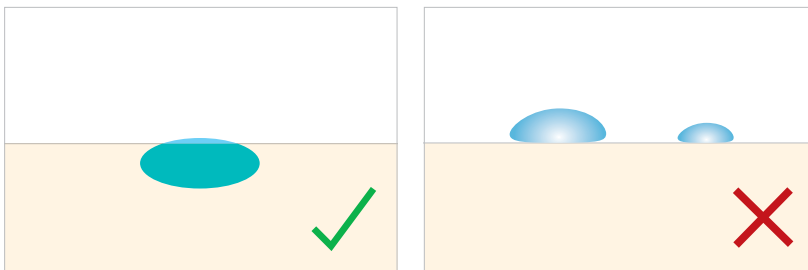

**Good absorbency**  
Drops are absorbed

**Insufficient absorbency**  
Drops pearl off

Some textiles and special finishes are **unsuitable** for Hotfix application, due to a **lack of absorbency**.

This is a list of **unsuitable** carrier materials and finishes:

- Very tightly woven textiles
- Very thin fabrics, e.g. tulle
- Smooth leather and smooth imitation leather
- Hydrophobic or water-repellent treatments (silicone, synthetic resin as a waterproofing agent)
- Teflon® coatings
- Stain-resistant treatments
- Easy-to-care treatments
- Fluorocarbon finishes
- Softening agents
- Select dyes (dyes with metal pigments)
- Enzymatic treatments

It can sometimes be helpful to wash the carrier material before application, in order to remove any unsuitable finishes (particularly softening agents), and thus improve absorbency.



Generally, the following parameters are most important when carrying out Hotfix applications of Swarovski products, depending on the consistency of the base material:

- Temperature
- Pressure
- Application time
- Application side

A detailed summary of all application parameters can be found in the Hotfix Selector table at the end of this chapter.

### Temperature

Swarovski Hotfix adhesive is activated within a temperature range of 120 °C to 170 °C (250 °F to 340 °F). A suitable application temperature can be selected from this range according to the carrier material and its sensitivity to heat. With heat presses, the temperature selected on the display does not always reflect the actual temperature on the surface of the press. Often, the temperature can be distributed unevenly, or one heat plate may be defective.

It is therefore recommended to regularly check the temperature with a laser measuring device or temperature measuring strips at various points on the heating surface, to ensure the temperature is distributed evenly across it. Checks should be carried out regularly (once per week), particularly during production.

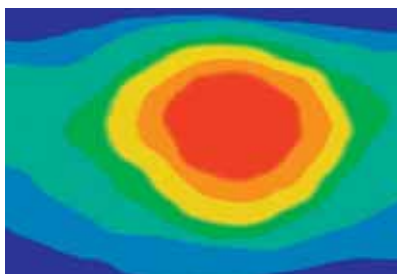

■ = 120 °C (250 °F)  
■ = 100 °C (212 °F)

**Uneven heat distribution** in the central area of the heat press

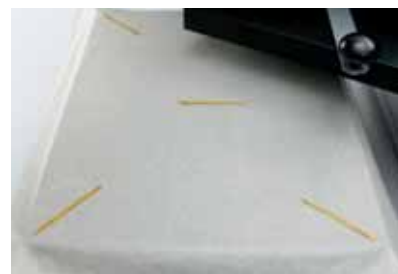

**Test with temperature measuring strips** (art. 9010/007)

### Pressure

The pressure setting depends on the Hotfix elements to be applied, the carrier material, and the technical equipment (machines, etc.) available.

Too much pressure can cause the adhesive to be spread out and can also affect the surface of the carrier material. Too little pressure, however, can result in a weak and insufficient bond between the crystal and the carrier material. In general, the pressure should be applied **directly to the crystal product** (e.g. Flat Backs Hotfix, Transfers, Crystal Mesh). It is therefore necessary to check if there are any buttons, zippers or other raised parts surrounding them. Always use a **compensating pad** to even out the surface.



**Jeans pocket**

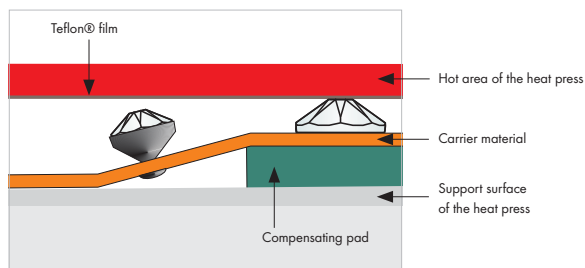

When applying Swarovski crystals of different heights, a **compensating pad** should always be used. Silicone foam, foam rubber or felt can be used here.

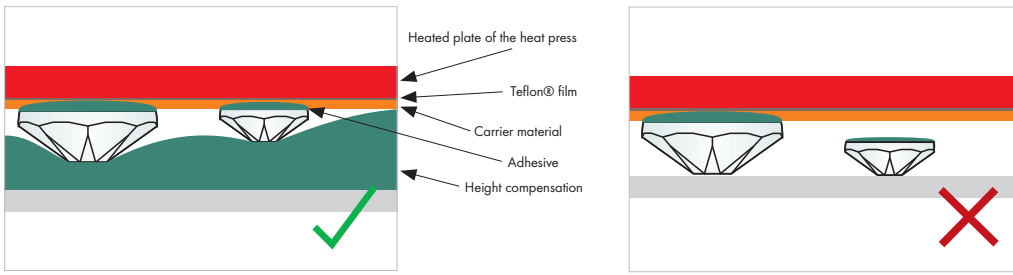

Height compensation with different Hotfix elements

### THE PARALLEL PLANE OF THE HEAT PRESS

Take great care to apply pressure evenly when using a heat press with a scissor mechanism. The upper plate of the heat press must be completely horizontal in order to effectively and evenly distribute pressure and temperature. ?!

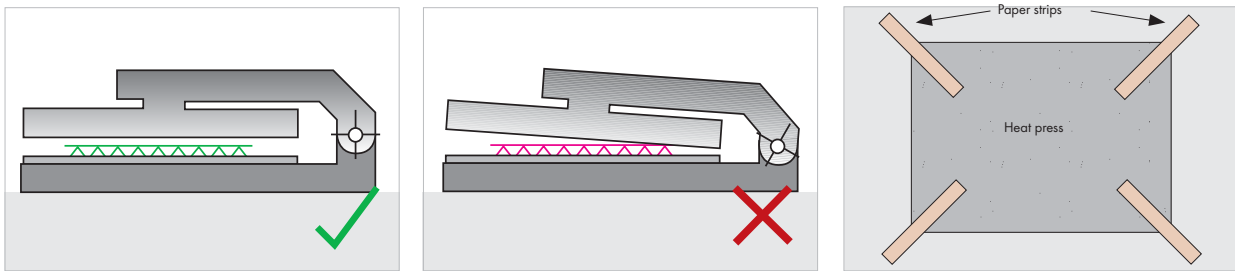

Checks should always be carried out to make sure the plates are parallel. This can be done by placing paper test strips into the press and closing it with the least possible pressure. After this, if it takes the same force to pull out each strip, the plates are parallel.

### Application time

In general, the application time should be sufficient to allow the hot-melt glue to be fully activated, and then to penetrate the carrier material.

The application time necessarily depends on the Hotfix elements, the temperature selected, the machine used, the carrier material and the application side.

A detailed summary can be found in the Hotfix Selector table at the end of this chapter. Please note that the times stated are intended as a guideline. When adapting them to your application, it is recommended to carry out tests on the original material.

### Application side

Hotfix elements can usually be applied from the front and the back. A shorter application time can be achieved with thinner fabrics by applying crystals from the back, as the heat reaches the adhesive through the carrier material faster, activating it immediately. ?!

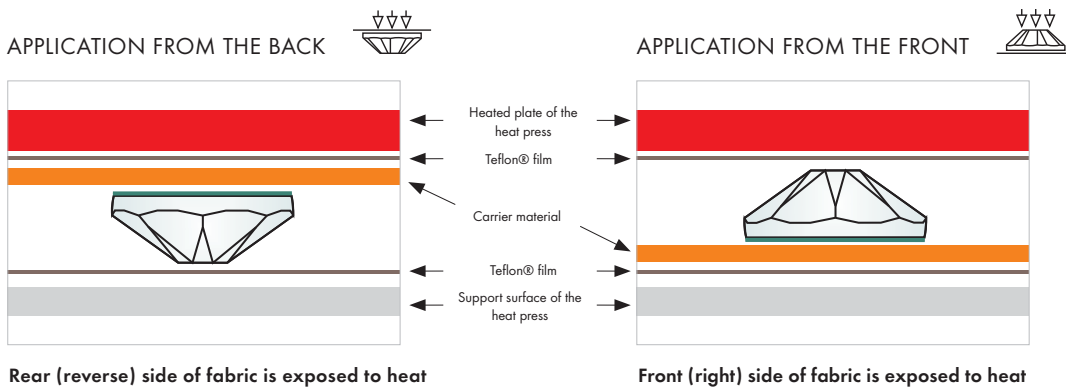

Rear (reverse) side of fabric is exposed to heat

Front (right) side of fabric is exposed to heat

When applying Hotfix products on **thick or multi-layered** fabrics (such as seams) the application side selected should be the one that allows the heat to be transferred to the hot-melt adhesive quickest. This ensures fast, optimum activation.

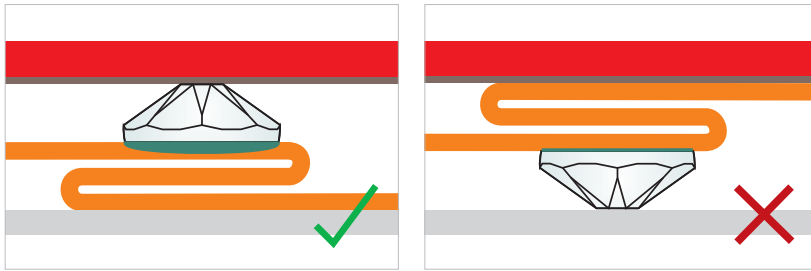

Selecting the optimum application side

Note that the shape and size (causing irregular temperature penetration) of many items (e.g. Crystal Pearls, Cabochons, Creation Stones Plus) will only allow an application **from the back**. Further information can be found in the Hotfix Selector table at the end of this chapter.

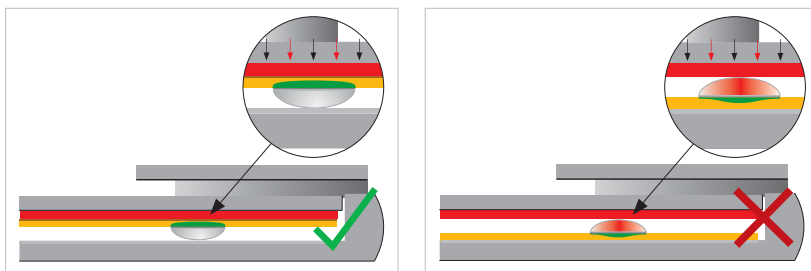

Certain Swarovski products can only be applied from the back.

### Defining the optimum application parameters

Adhesive has been successfully activated when, using a magnifying glass, it is possible to see a thin edge of glue formed around the crystal. On thin fabrics, the optimum application parameters are chosen when the glue will have lightly penetrated through the fabric and is lightly visible at the reverse.

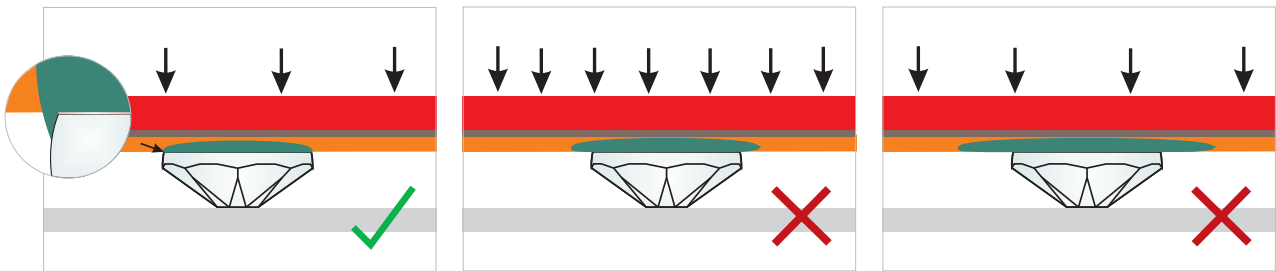

Optimum application result

Huge excess of glue – too much pressure exerted with heat press

Huge excess of glue – heat press temperature too high, or applied too long

When parameters have been incorrectly selected, such as an extreme application temperature, pressure, or application time, significant amounts of glue can spread out.

When the application temperature or pressure is too low, or the application time too short, the adhesive cannot be sufficiently activated, leading to problems with adhesion.

### Application using a heat press

A heat press is the ideal tool for applying Hotfix products as it can be used to apply even, adjustable pressure. All Swarovski products mentioned in the product overview can be applied using the following steps. Please also note the helpful hints concerning the application of Crystal Mesh and Diamond Transfers.

To adjust the application parameters and the aids to achieve an ideal balance, it is strongly recommended that tests are carried out with the original material.



1 Peel off the white protective film\*.



2 Place the product in the desired position.



3 Make sure to apply the elements from the recommended side and use the correct pressing aid. To protect the heating surfaces from any glue residue, it is best to cover them with Teflon® film.



4 After pressure, time and temperature are set, close the heat press.



5 After the application is finished, use a pressing cloth to apply additional pressure to the product.



6 Once the product is at least hand warm, the transparent film can be removed at an acute angle.

\* If the adhesion is insufficient after the application process, the whole process can be repeated, adjusting the parameters (such as pressure, time, and temperature). Please ensure that the application process is repeated from the very beginning, and that the initial application time is combined with the additional time.

For example: An application time of 10 seconds was not sufficient. Pressure should not just be applied for a further 5 seconds – the process must be repeated in its entirety, with an application time of 15 seconds.



### Application using a continuous fusing press

Transfers and other Hotfix Banding variants can be applied using a continuous fusing press. This type of application offers a simple, efficient way of joining the carrier material and the Hotfix product as part of a continuous application process.

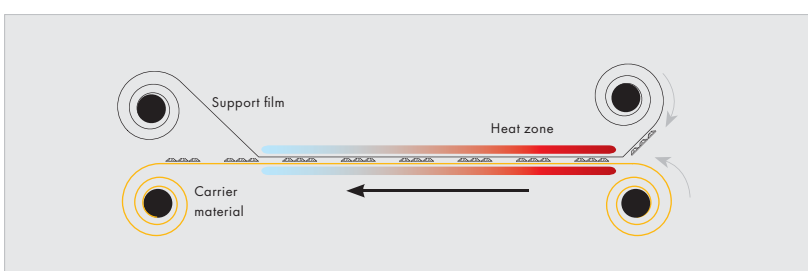

Continuous fusing press operation

With most continuous fusing presses, heat is generated on both sides. The speed of the press, pressure and temperature should be selected to ensure that the time in the heat zone corresponds to the figures in the Hotfix Selector table (see the end of this chapter). This time can be calculated using the length of the heat zone and the speed selected.

### Application using an ultrasonic device

Art. 2078 XIRIUS Flat Back Hotfix (SS 12 – SS 34), art. 2038 XILION Flat Back Hotfix (SS 6 – SS 10) and some Creation Stones (e.g. Rivoli cuts art. 2716, 2816, 2826) can quickly and easily be applied using an ultrasonic device. In this process, the hot-melt adhesive is activated via **friction heat**, created through the quick vibrations and simultaneous pressing down of the Flat Backs onto the carrier material.

A device with a vacuum pump is best for correctly positioning the crystals. Alternatively, they can also be positioned using transfer film or tweezers, and then applied via ultrasonic.

The frequency of the ultrasonic device must be precisely set according to the manufacturer's instructions. Some manufacturers also offer devices with automatic frequency setting. The application time is then selected according to pretests.



1 Choose an adapter to match the size of the crystal.



2 Position the crystal on the carrier material, which should be resting on a solid base (e.g. glass, metal).



3 Press the adapter firmly onto the crystal at a perpendicular angle and activate the device.

### Application using a stone setting machine

Hotfix crystals can be secured with a stone setting machine using either ultrasonic or heat. The feed and application of the crystals is either fully or semi-automatic.



Stone setting machine

### Application using an applicator

Applicators are a cost-effective way to apply art. 2078 XIRIUS Flat Back Hotfix (SS 12 – SS 34) and art. 2038 XILION Flat Back Hotfix (SS 6 – SS 10) onto the carrier material.



1 Choose an applicator point to match the size of the crystal, so that the crystal cannot tilt out of place or use a plain applicator point.



2 Heat the applicator to a suitable temperature and pick up the crystal.



3 As soon as the Hotfix adhesive on the rear of the crystal has melted, position the element on the carrier material, which should be resting on a solid base (e.g. glass, metal).

Note: Heat sensitive fabrics can be damaged by high temperatures of the applicator point.



### Application using an iron

In general, an iron can be used for the application of all Hotfix elements. However, as pressure and temperature can only be controlled to a **limited extent**, the use of a heat press is recommended.

Always make sure that there are no **steam vents** on the soleplate of the iron. Pressure cannot be applied at these vents, and water droplets and steam have a negative effect on the application results. Always iron on a firm, flat, and even base.



### EXPLANATION OF DOT SYSTEM ACCORDING TO DIN EN ISO 3758

- Soleplate temperature 110 °C (230 °F)
- Soleplate temperature 150 °C (302 °F)
- Soleplate temperature 200 °C (392 °F)



1 Select symbol •• (max. 150 °C/302 °F).



2 Use felt or cardboard to prevent the crystal elements from marking the fabric.



3 A Teflon® underlay protects the soleplate of the iron from any glue residue.



Hot-melt adhesive generally requires 24 hours to cure completely. Any washing or quality assurance should take place after this period.



## USEFUL INFORMATION

### Pre-cut fabric

Experience has shown that the best results are obtained with applications on pre-cut fabric. In order to obtain optimum adjustment of all application parameters, advance testing on the materials to be used is strongly recommended before production begins.

### Cutting Crystal Mesh

Before Hotfix application, the transparent film must not be removed. The film allows the individual crystals to be aligned perfectly, and provides Crystal Mesh with the stability necessary for flawless application.

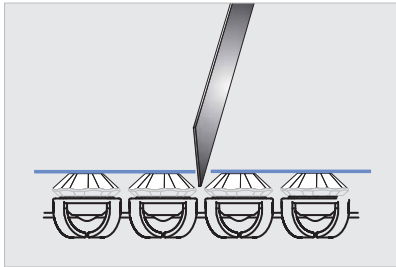

1 Cut between the rows of crystals with a Stanley knife, but do not pull them apart, otherwise the stability of the crystals will be lost.



2 Cut the metal mesh with scissors along the scored line, and remove the excess link rings. The Crystal Mesh is now ready for Hotfix application.

### Cutting Crystaltex Chaton Bandings and Cabochon Bandings

When working with Crystaltex Chaton Bandings and Cabochon Bandings, the lack of space between crystals means great care must be taken during cutting, so as to avoid any damage.

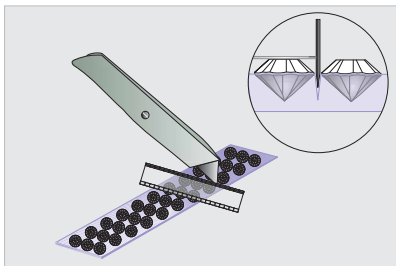

1 Cut into the carrier material between the crystal rows with a Stanley knife.

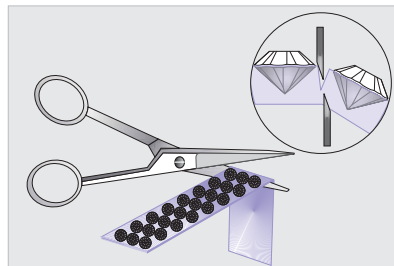

2 Snap and cut off the Crystaltex Chaton Banding and Cabochon Banding along the scored edge.

### Avoiding film marks

Undesired film marks on sensitive fabrics can be avoided by cutting the transparent film close **to the edge of the motif**. Apply the product for a short time, using a small amount of pressure. Then remove the transparent film and press again following the recommended time and pressure settings.

?!

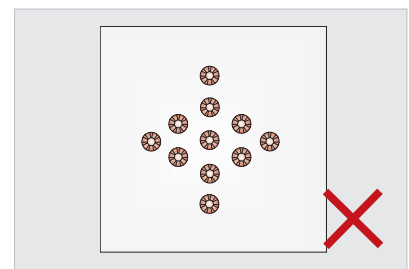
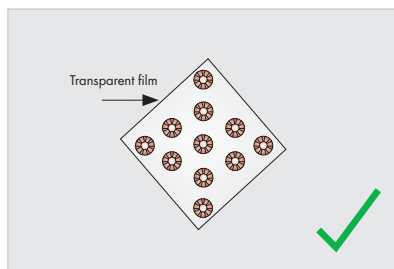

If the film has already left marks, the surface structure of the carrier material can usually be restored by brushing, using a steam iron or by re-pressing it in the heat press.

## Hotfix application on other materials

The Hotfix glue was specially developed for use with textiles. However, experience shows that Hotfix applications can also be carried out on other materials such as wood, paper or metal. In such cases it is very important to carry out application tests beforehand, and to check the surface properties (see surface tension in the "Gluing" chapter).

## Application instructions for Diamond Transfers

When applying Diamond Transfers (Transfers with high-brilliance Chatons: art. 1028 XILION Chaton for sizes PP 7 and PP 12, art. 1088 XIRIUS Chaton for PP 17), a **soft, compensating underlay** (e.g. Silicone pad art. 9010/005) should always be used. This soft pad encloses the crystal points, and allows the optimum distribution of pressure, thus improving the bond between the carrier material and the Diamonds (adhesion right up to the girdle). Cardboard prevents the crystals from sinking into the soft support surface of the heat press, and ensures the proper application of pressure.

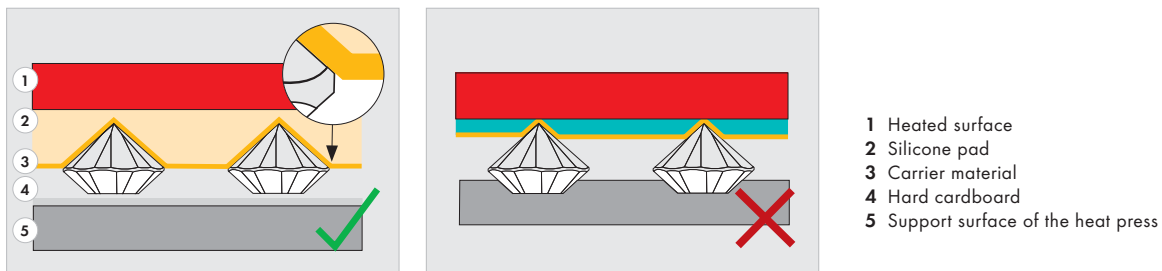

A soft silicone pad offers optimum distribution of pressure and allows adhesion right up to the girdle.

Without a pressure compensator, adhesion only occurs at the contact points with the heated plate.

## Diamond Transfers on solid materials

To apply Diamond Transfers on solid, wooden-based surfaces carry out the following instructions:

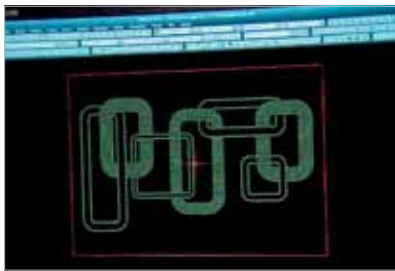

1 To program the CNC milling machine with the requested Diamond motif the individual .dxf file is required. Contact your Swarovski sales office to request this file.



2 Mill the cavities using a special 90° mill with a diameter that corresponds to the selected element. Clean the surface carefully using oil-free compressed air afterwards.



3 For an easier removal of the transfer film after the application, apply a small transfer foil on the edge of the carrier material.



4 Peel off the Diamond Transfer's white protective film and place the Diamond Transfer in the desired position on the carrier material. The transfer film is lying on the small transfer foils, too.



5 Carefully clean the contact surfaces of the heat press while turned off. Position the carrier material in the heat press and set the application parameters. Make sure that the right application aids are used.



6 After the application is finished, use a pressing cloth or a heat resistant glove to apply additional pressure.



7 Once the product has cooled down completely, the transparent film can be removed at an acute angle with help of the applied transfer foil.

We do not recommend the application of Diamond Transfer on following fields of application:

- In baths and wellness areas, due to high temperature and moisture
- In contact with sweat, chlorine and other aggressive cleaning agents
- Outdoors

For further information visit [SWAROVSKI.COM/PROFESSIONAL](http://SWAROVSKI.COM/PROFESSIONAL)

#### CAVITY PRODUCTION/TYPES

Specific cavities need to be created when applying Diamond Transfers onto a carrier material with a solid surface. The cavity enables the Transfer to be easily positioned and ensures a higher protection of the crystal against mechanical and chemical stress. These cavities can be produced by milling (e.g. with CNC machines). The individual .dxf file which is needed to program the machine includes position information (centre point of each diamond). It can be read by standard CNC machines.

For detailed information and instructions about cavity production/types please refer to the “Gluing” chapter.

ART. 1360	CAVITY ANGLE	ADDITIONAL COUNTERSINK	TWIST/NC DRILL 90° DIAMETER
PP 7	90°	0.10 mm	1.5 mm
PP 12			2.0 mm
PP 17			2.5 mm

#### HOTFIX APPLICATION OF DIFFERENT STONE SIZES

A Hotfix application of one motif with different stone sizes is not possible in only one application step. In this case the specific design must be divided into separate motifs, which in turn must be applied separately, starting with the Diamond Transfers that feature the smallest stone.

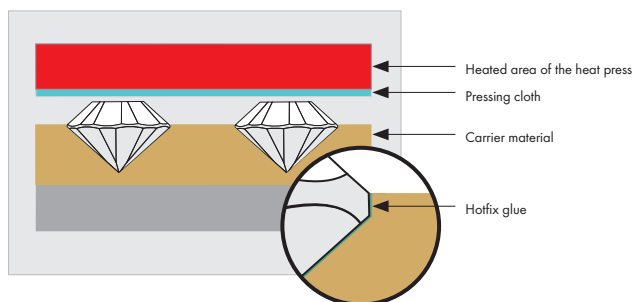

## QUICK ASSISTANCE

The following table outlines common problems and their causes when applying Hotfix elements, and offers advice on how to avoid them. Further details and more extensive descriptions can be found in the section marked with a **?!**

PROBLEM	CAUSE
The product does not adhere to the fabric.	<b>1, 2, 3, 4, 5, 6</b>
Glue is oozing out around the crystals.	<b>7, 8, 9, 10</b>
The support film leaves marks on delicate fabrics.	<b>7, 8, 9, 10, 11, 12</b>
The product does not adhere to seams or multi-layered fabric.	<b>1, 2, 3, 4, 5, 6, 13</b>

CAUSE	RECOMMENDATION
<b>1</b> The application temperature is too low.	Increase the temperature to at least 120 °C (250 °F). See the Hotfix Selector table for further assistance.
<b>2</b> Uneven distribution of heat on the heated surface.	Check the temperature with a temperature measuring strip or a laser measuring device, and set up the heat press again.
<b>3</b> The application time is too short.	Increase application time; it takes longer for the heat to activate the Hotfix glue on layered fabric and seams; if necessary apply from the front. See the Hotfix Selector table for further assistance.
<b>4</b> The pressure is too low.	Thick fabrics and certain products need higher pressure. See the Hotfix Selector table for further assistance.
<b>5</b> The heat press does not close evenly.	Adjust the heat press.
<b>6</b> The ironing pad is unsuitable.	Carry out tests with different ironing pads to establish the most suitable.
<b>7</b> The temperature is too high.	Choose a lower temperature, between 120 °C and 170 °C (250 °F - 340 °F). See the Hotfix Selector table for further assistance.
<b>8</b> The application time is too long.	Reduce the application time. See the Hotfix Selector table for further assistance.
<b>9</b> The pressure is too high.	Reduce the pressure on the heat press. See the Hotfix Selector table for further assistance.
<b>10</b> The ironing pad is too hard.	Use a soft silicone pad.
<b>11</b> The fabric is extremely sensitive.	Iron the fabric with a steam iron.
<b>12</b> The transparent support film leaves marks.	Cut away more of the film, closer to the edge of the motif, to reduce marking.
<b>13</b> Hotfix elements are not being affected by the heat plate.	Balance out the different thicknesses of seams, buttons, zippers etc. by using pieces of felt, which have been cut to exactly the right size and placed under the Hotfix element.

## SWAROVSKI HOTFIX SELECTOR

The Hotfix Selector table contains information on the application parameters









- temperature
- pressure
- application time
- application side

for various Swarovski products and material combinations. The figures given are for Hotfix application using a heat press.

**Note:** The temperature/time combinations in the Hotfix Selector table are only guidelines. Please note that too high temperature or too long application times might decrease the final bonding. Pressure cannot be specified more exactly, as this depends on the setting options of the press closure system (manual, pneumatic, hydraulic or electromagnetic). In all cases, tests should be carried out from the start of production, to ensure the ideal combination of settings for the design. The figures listed are valid until further notice.

PRODUCT	DESCRIPTION	TYPE OF SELECTOR	
<b>Transfers</b>	XIRIUS Transfers	Transfers with XIRIUS Flat Backs Hotfix (art. 2078)	Hotfix Selector 1, page 103
	XILION Transfers	Transfers with XILION Flat Backs Hotfix (art. 2038)	Hotfix Selector 1, page 103
	Creation Transfers	Transfers combined with Creation Stones (e.g. art. 2200, 2300) or (Pearl) Cabochons (2080/4). Stone size: max. 8 mm	Hotfix Selector 2, page 103
	Creation Transfers Plus	Transfers combined with Creation Stones Plus (e.g. art. 2493, 2555). Stone size >8 mm	Hotfix Selector 3, page 104
	Pearl Transfers	Transfers with Pearls	Hotfix Selector 2, page 103
	Diamond Transfers	Transfers with Diamonds (stone size: PP 7/12/17)	Hotfix Selector 4, page 104*
	Metallic Transfers	Transfers with Metallics	Hotfix Selector 2, page 103
	Mezzo Transfers	Metallic Transfers combined with XILION and XIRIUS Flat Backs, Pearls or Creation Stones	Hotfix Selector 2, page 103
	Framed Flat Back Transfers	Transfers with Framed Flat Backs	Hotfix Selector 11, page 108
<b>Synthetics Hotfix</b>	Crystal Fabric, Graphic Fabric and Crystal Medley	Carrier material is completely covered with tiny cut and uncut crystals	Hotfix Selector 5, page 105
	Crystal Rocks and Graphic Rocks	Carrier material is covered with large double-pointed Chatons (stone size: PP 22)	Hotfix Selector 7, page 106
	Crystal Fine Rocks and Graphic Fine Rocks	Carrier material is covered with small double-pointed Chatons (stone size: PP 14)	Hotfix Selector 8, page 106
	Crystaltex	Differently colored carrier material with XILION Flat Backs	Hotfix Selector 6, page 105
	Crystaltex Chaton	Small XILION Chatons laid on a transparent base material	Hotfix Selector 5, page 105
	Crystaltex Cabochon	Carrier material is covered with Cabochons	Hotfix Selector 5, page 105
<b>Crystal Mesh</b>	Crystal Mesh Standard	Flexible metal mesh carrier with integrated loose crystals (stone size: PP 21)	Hotfix Selector 9, page 107
	Crystal Mesh XL	Flexible metal mesh carrier with integrated loose crystals (stone size: SS 24)	Hotfix Selector 10, page 107
	Crystal Mesh Metallisée	Flexible metal mesh carrier with integrated loose crystals and metallic parts (stone size: PP 21)	Hotfix Selector 9, page 107
	Crystal Aerial Mesh	Flexible metal mesh carrier with integrated loose crystals (stone size: PP 14)	Hotfix Selector 9, page 107
	Crystal Fine Mesh	Flexible metal mesh carrier with integrated loose crystals (stone size: PP 9)	Hotfix Selector 9, page 107

\* For application on textiles and on solid materials.

FABRIC CATEGORY	FABRIC EXAMPLE	MATERIAL	WEIGHT
Reference fabric	 Cotton/polyester blend	65% cotton, 35% polyester	190 g/m <sup>2</sup>
Natural fibers	 Batiste, Vichy fabric, cotton jersey, interlock, linen fabrics, etc.	Cotton, linen	100 - 200 g/m <sup>2</sup>
	 Silk fabrics, toile, etc.	Silk	100 - 200 g/m <sup>2</sup>
	 Jeans, denim, cord, velvet, damask, gabardine, sweatshirt fabrics, etc.	Cotton	300 - 400 g/m <sup>2</sup>
	 Cloth, tweed, bouclé, loden, boiled wool, felt, knitted fabrics, etc.	Wool	300 - 400 g/m <sup>2</sup>
Cellulose and synthetic fibers	 Viscose, satin, organza, chiffon, taffeta, tulle, lace, etc.	Viscose, acetate, triacetate, polyester, polyamide, polyacrylics and various fiber blends	20 - 120 g/m <sup>2</sup>
	 LYCRA®, neoprene, etc.		150 - 250 g/m <sup>2</sup>
Pile fabrics	 Artificial leather, alcantara, suede, fleece, artificial fur, plush, toweling, etc.	Cottons, various fiber blends	200 - 350 g/m <sup>2</sup>

As most Swarovski products can be applied from the front or back, the Hotfix Selector table features the application parameters for both sides. Extensive information on optimum application, depending on the production process and the application type (e.g. on trouser pockets), is available.

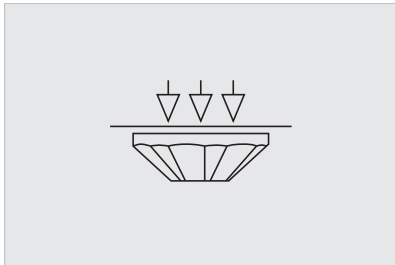

**Back:** The back (reverse) of the fabric is exposed to the heat press.

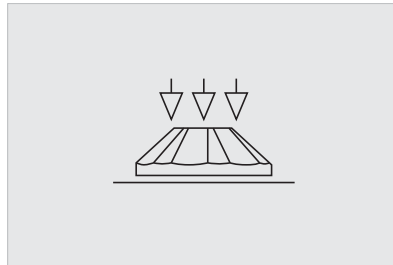

**Front:** The front (right side) of the fabric is exposed to the heat press.

The temperature settings selected depend on the heat resistance of the carrier material, and should be judged by the customer. The higher the temperature, the less time is required to activate the Hotfix adhesive (see table/chart). The application time depends primarily on the textile used and its thickness.

### Aids

- Teflon® (100x50 cm, 40x20 inches, art. 9010/003)
- Silicone ironing pad (foam) (134x100 cm, 54x40 inches, art. 9010/002)
- Silicone pad (50x50x0.2 cm, 20x20x0.08 inches, art. 9010/005)
- Felt
- Standard pressing cloth (cotton)
- Standard cardboard
- Transfer film ([www.dso-co.com](http://www.dso-co.com), [www.strass.cc](http://www.strass.cc))

# HOTFIX SELECTOR 1

## XILION TRANSFERS/XIRIUS TRANSFERS

### APPLICATION FROM THE FRONT



	Temperature/time required (in seconds)					
	120 °C	130 °C	140 °C	150 °C	160 °C	170 °C
	250 °F	265 °F	285 °F	300 °F	320 °F	340 °F

Reference fabric	50	42	36	30	24	18
Silk, batiste, cotton jersey, thin linen fabrics, etc.	46	38	32	26	20	15
Jeans, cord, loden, cloth, knitted fabrics, etc.	55	45	35	30	25	20
Viscose, satin, chiffon, organza, taffeta, etc.	48	40	34	28	22	16
LYCRA®, neoprene, etc.	52	44	38	32	25	18
Artificial fur, artificial leather, fleece, suede, etc.	60	50	42	34	26	20

Pressure: low

Aids: Teflon®, pressing cloth, silicone foam

Note: The application time depends primarily on the size of the crystal.

To offer an average, figures are given for crystal size SS 20 (art. 2078).

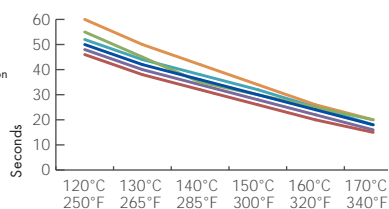

### APPLICATION FROM THE BACK



	Temperature/time required (in seconds)					
	120 °C	130 °C	140 °C	150 °C	160 °C	170 °C
	250 °F	265 °F	285 °F	300 °F	320 °F	340 °F

Reference fabric	20	17	14	11	8	6
Silk, batiste, cotton jersey, thin linen fabrics, etc.	15	13	11	9	7	5
Jeans, cord, loden, cloth, knitted fabrics, etc.	25	23	21	18	15	12
Viscose, satin, chiffon, organza, taffeta, etc.	12	10	8	7	6	5
LYCRA®, neoprene, etc.	35	30	25	18	13	8
Artificial fur, artificial leather, fleece, suede, etc.	50	40	35	30	25	20

Pressure: low

Aids: Teflon®, pressing cloth, silicone foam

Note: XIRIUS Transfers with size SS 40 and SS 48 should be applied like Creation Stones Plus (page 102)

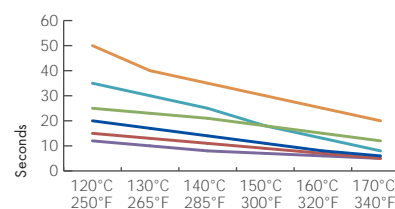

# HOTFIX SELECTOR 2

## CREATION TRANSFERS, PEARL TRANSFERS, METALLIC TRANSFERS & MEZZO TRANSFERS

Pearl Transfers are **NOT** suitable for application from the front!

### APPLICATION FROM THE FRONT



	Temperature/time required (in seconds)					
	120 °C	130 °C	140 °C	150 °C	160 °C	170 °C
	250 °F	265 °F	285 °F	300 °F	320 °F	340 °F

Reference fabric	55	46	40	34	28	22
Silk, batiste, cotton jersey, thin linen fabrics, etc.	50	42	36	30	24	18
Jeans, cord, loden, cloth, knitted fabrics, etc.	60	50	40	35	30	25
Viscose, satin, chiffon, organza, taffeta, etc.	52	44	38	32	26	20
LYCRA®, neoprene, etc.	58	50	42	36	30	22
Artificial fur, artificial leather, fleece, suede, etc.	62	52	45	38	30	22

Pressure: medium

Aids: Teflon®, pressing cloth, silicone foam

Note: The application time depends primarily on the largest element in the motif.

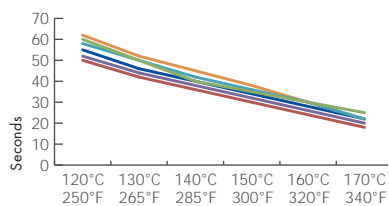

### APPLICATION FROM THE BACK



	Temperature/time required (in seconds)					
	120 °C	130 °C	140 °C	150 °C	160 °C	170 °C
	250 °F	265 °F	285 °F	300 °F	320 °F	340 °F

Reference fabric	25	23	19	16	12	9
Silk, batiste, cotton jersey, thin linen fabrics, etc.	27	24	20	16	12	8
Jeans, cord, loden, cloth, knitted fabrics, etc.	25	23	21	18	15	12
Viscose, satin, chiffon, organza, taffeta, etc.	18	16	14	11	8	5
LYCRA®, neoprene, etc.	38	32	26	20	15	10
Artificial fur, artificial leather, fleece, suede, etc.	55	46	40	34	28	22

Pressure: medium

Aids: Teflon®, pressing cloth, silicone foam

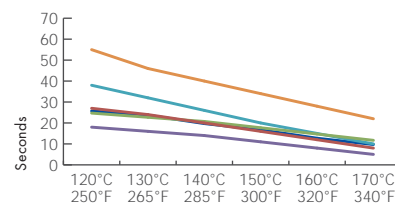

## HOTFIX SELECTOR 3

### CREATION TRANSFERS PLUS

These items are **NOT** suitable for application from the front!

#### APPLICATION FROM THE FRONT



#### APPLICATION FROM THE BACK



Temperature/time required (in seconds)  
 120 °C 130 °C 140 °C 150 °C 160 °C 170 °C  
 250 °F 265 °F 285 °F 300 °F 320 °F 340 °F

Reference fabric	35	35	30	25	18	12
Silk, batiste, cotton jersey, thin linen fabrics, etc.	30	28	25	20	15	10
Jeans, cord, loden, cloth, knitted fabrics, etc.	40	38	32	28	22	16
Viscose, satin, chiffon, organza, taffeta, etc.	28	25	22	18	12	10
LYCRA®, neoprene, etc.	38	35	30	25	18	12
Artificial fur, artificial leather, fleece, suede, etc.	50	40	35	30	25	20

Pressure: medium

Aids: Teflon®, pressing cloth

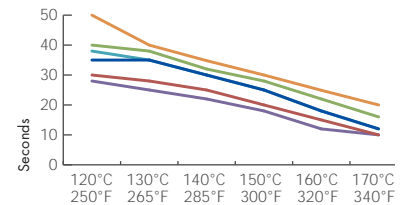

## HOTFIX SELECTOR 4

### DIAMOND TRANSFERS

#### APPLICATION FROM THE FRONT



Temperature/time required (in seconds)  
 110 °C 120 °C 130 °C 140 °C 150 °C 160 °C 170 °C  
 230 °F 250 °F 265 °F 285 °F 300 °F 320 °F 340 °F

Reference fabric	-	-	-	80	60	45	35
Silk, batiste, cotton jersey, thin linen fabrics, etc.	-	-	-	65	50	40	30
Jeans, cord, loden, cloth, knitted fabrics, etc.	-	-	-	65	48	35	28
Viscose, satin, chiffon, organza, taffeta, etc.	-	-	-	-	-	-	-
LYCRA®, neoprene, etc.	-	-	-	50	40	30	20
Artificial fur, artificial leather, fleece, suede, etc.	-	-	-	55	42	32	22
Medium density fiberboard (MDF)	120	-	-	-	-	-	-
Veneered wood fiberboard	120	-	-	-	-	-	-
Laminated wood fiberboard (HPL)	120	-	-	-	-	-	-
Solid hardwood	120	-	-	-	-	-	-

Pressure: high

Aids: Teflon®, pressing cloth, cardboard, preheated silicone pad

Note: Diamond Transfers are best suited to soft, voluminous fabrics.

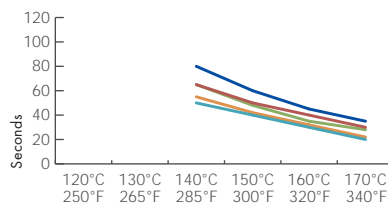

#### APPLICATION FROM THE BACK



Temperature/time required (in seconds)  
 120 °C 130 °C 140 °C 150 °C 160 °C 170 °C  
 250 °F 265 °F 285 °F 300 °F 320 °F 340 °F

Reference fabric	-	-	110	50	30	25
Silk, batiste, cotton jersey, thin linen fabrics, etc.	-	-	120	60	40	35
Jeans, cord, loden, cloth, knitted fabrics, etc.	-	-	110	55	35	30
Viscose, satin, chiffon, organza, taffeta, etc.	-	-	-	-	-	-
LYCRA®, neoprene, etc.	-	-	90	40	20	15
Artificial fur, artificial leather, fleece, suede, etc.	-	-	100	55	35	25

Pressure: high

Aids: Teflon®, pressing cloth, cardboard, preheated silicone pad

Note: Diamond Transfers are best suited to soft, voluminous fabrics.

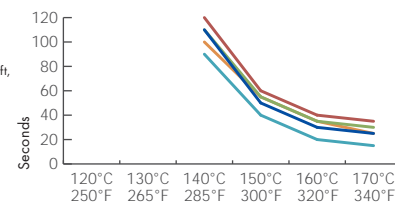



## HOTFIX SELECTOR 5

**CRYSTAL FABRIC, GRAPHIC FABRIC, CRYSTAL MEDLEY,  
CRYSTALTEX CHATON & CRYSTALTEX CABOCHON\***

### APPLICATION FROM THE FRONT



Temperature/time required (in seconds)  
 120 °C 130 °C 140 °C 150 °C 160 °C 170 °C  
 250 °F 265 °F 285 °F 300 °F 320 °F 340 °F

Reference fabric	-	-	50	45	40	35
Silk, batiste, cotton jersey, thin linen fabrics, etc.	-	-	45	40	35	30
Jeans, cord, loden, cloth, knitted fabrics, etc.	-	-	55	50	45	40
Viscose, satin, chiffon, organza, taffeta, etc.	-	-	35	30	25	20
LYCRA®, neoprene, etc.	-	-	40	35	30	25
Artificial fur, artificial leather, fleece, suede, etc.	-	-	38	32	27	22

Pressure: medium  
 Aids: Teflon®, pressing cloth

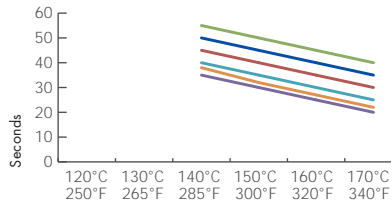

### APPLICATION FROM THE BACK



Temperature/time required (in seconds)  
 120 °C 130 °C 140 °C 150 °C 160 °C 170 °C  
 250 °F 265 °F 285 °F 300 °F 320 °F 340 °F

Reference fabric	-	-	50	45	40	35
Silk, batiste, cotton jersey, thin linen fabrics, etc.	-	-	45	40	35	30
Jeans, cord, loden, cloth, knitted fabrics, etc.	-	-	60	55	50	45
Viscose, satin, chiffon, organza, taffeta, etc.	-	-	35	30	25	20
LYCRA®, neoprene, etc.	-	-	45	40	35	30
Artificial fur, artificial leather, fleece, suede, etc.	-	-	42	38	32	26

Pressure: medium  
 Aids: Teflon®, pressing cloth

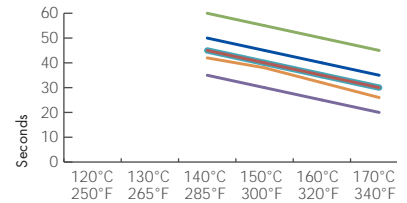

## HOTFIX SELECTOR 6

**CRYSTALTEX**

### APPLICATION FROM THE FRONT



Temperature/time required (in seconds)  
 120 °C 130 °C 140 °C 150 °C 160 °C 170 °C  
 250 °F 265 °F 285 °F 300 °F 320 °F 340 °F

Reference fabric	40	35	30	25	20	15
Silk, batiste, cotton jersey, thin linen fabrics, etc.	42	38	32	26	22	18
Jeans, cord, loden, cloth, knitted fabrics, etc.	45	40	35	30	25	20
Viscose, satin, chiffon, organza, taffeta, etc.	42	38	32	26	22	18
LYCRA®, neoprene, etc.	40	35	30	25	20	15
Artificial fur, artificial leather, fleece, suede, etc.	45	40	35	30	25	22

Pressure: medium  
 Aids: Teflon®, pressing cloth

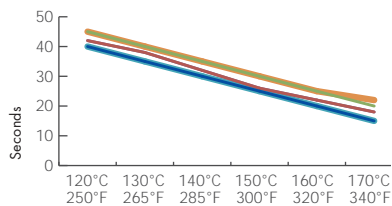

### APPLICATION FROM THE BACK



Temperature/time required (in seconds)  
 120 °C 130 °C 140 °C 150 °C 160 °C 170 °C  
 250 °F 265 °F 285 °F 300 °F 320 °F 340 °F

Reference fabric	30	25	20	15	12	10
Silk, batiste, cotton jersey, thin linen fabrics, etc.	35	30	25	20	15	12
Jeans, cord, loden, cloth, knitted fabrics, etc.	40	34	28	22	16	12
Viscose, satin, chiffon, organza, taffeta, etc.	20	18	16	13	11	8
LYCRA®, neoprene, etc.	28	22	18	15	12	10
Artificial fur, artificial leather, fleece, suede, etc.	42	36	30	24	18	15

Pressure: medium  
 Aids: Teflon®, pressing cloth

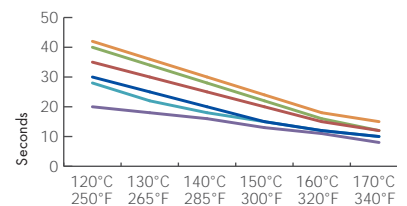

\* Due to the crystals' lacquer it is recommended applying Crystaltex Cabochons from the back. If applying them from front side, make sure to protect the crystals by using a felt or a rubber foam.

## HOTFIX SELECTOR 7

### CRYSTAL ROCKS, GRAPHIC ROCKS

#### APPLICATION FROM THE FRONT



	Temperature/time required (in seconds)					
	120 °C	130 °C	140 °C	150 °C	160 °C	170 °C
	250 °F	265 °F	285 °F	300 °F	320 °F	340 °F

Reference fabric	-	-	80	65	50	45
Silk, batiste, cotton jersey, thin linen fabrics, etc.	-	-	75	60	45	40
Jeans, cord, loden, cloth, knitted fabrics, etc.	-	-	100	80	60	50
Viscose, satin, chiffon, organza, taffeta, etc.	-	-	70	55	40	35
LYCRA®, neoprene, etc.	-	-	75	60	45	40
Artificial fur, artificial leather, fleece, suede, etc.	-	-	70	60	45	35

Pressure: medium

Aids: Teflon®, pressing cloth

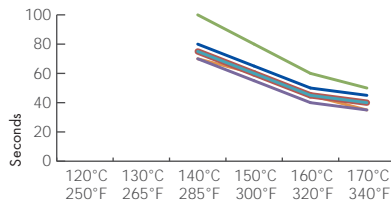

#### APPLICATION FROM THE BACK



	Temperature/time required (in seconds)					
	120 °C	130 °C	140 °C	150 °C	160 °C	170 °C
	250 °F	265 °F	285 °F	300 °F	320 °F	340 °F

Reference fabric	-	-	80	65	50	40
Silk, batiste, cotton jersey, thin linen fabrics, etc.	-	-	70	55	45	35
Jeans, cord, loden, cloth, knitted fabrics, etc.	-	-	100	80	60	50
Viscose, satin, chiffon, organza, taffeta, etc.	-	-	70	55	40	35
LYCRA®, neoprene, etc.	-	-	80	65	50	40
Artificial fur, artificial leather, fleece, suede, etc.	-	-	75	60	45	35

Pressure: medium

Aids: Teflon®, pressing cloth

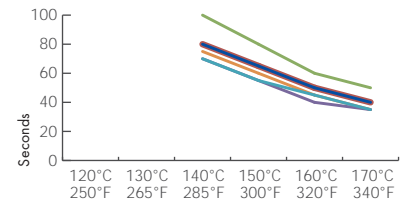

## HOTFIX SELECTOR 8

### CRYSTAL FINE ROCKS, GRAPHIC FINE ROCKS

#### APPLICATION FROM THE FRONT



	Temperature/time required (in seconds)					
	120 °C	130 °C	140 °C	150 °C	160 °C	170 °C
	250 °F	265 °F	285 °F	300 °F	320 °F	340 °F

Reference fabric	-	-	70	60	50	45
Silk, batiste, cotton jersey, thin linen fabrics, etc.	-	-	65	55	45	40
Jeans, cord, loden, cloth, knitted fabrics, etc.	-	-	80	70	60	50
Viscose, satin, chiffon, organza, taffeta, etc.	-	-	60	50	40	30
LYCRA®, neoprene, etc.	-	-	65	55	40	35
Artificial fur, artificial leather, fleece, suede, etc.	-	-	60	50	40	30

Pressure: medium

Aids: Teflon®, pressing cloth

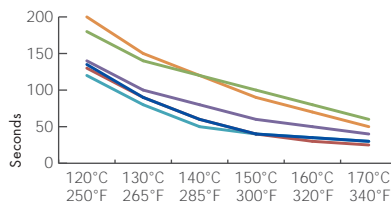

#### APPLICATION FROM THE BACK



	Temperature/time required (in seconds)					
	120 °C	130 °C	140 °C	150 °C	160 °C	170 °C
	250 °F	265 °F	285 °F	300 °F	320 °F	340 °F

Reference fabric	-	-	80	65	50	40
Silk, batiste, cotton jersey, thin linen fabrics, etc.	-	-	70	55	45	35
Jeans, cord, loden, cloth, knitted fabrics, etc.	-	-	100	80	60	50
Viscose, satin, chiffon, organza, taffeta, etc.	-	-	70	55	40	35
LYCRA®, neoprene, etc.	-	-	80	65	50	40
Artificial fur, artificial leather, fleece, suede, etc.	-	-	75	60	45	35

Pressure: medium

Aids: Teflon®, pressing cloth, transfer film to fix in place

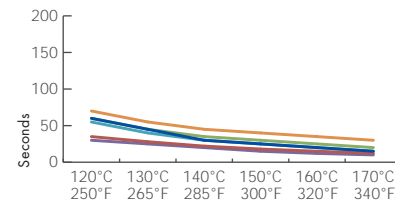

# HOTFIX SELECTOR 9

## CRYSTAL MESH (STANDARD, AERIAL, METALLISÉE & CRYSTAL FINE MESH)

### APPLICATION FROM THE FRONT



	Temperature/time required (in seconds)					
	120 °C	130 °C	140 °C	150 °C	160 °C	170 °C
	250 °F	265 °F	285 °F	300 °F	320 °F	340 °F

Reference fabric	135	90	60	40	35	30
Silk, batiste, cotton jersey, thin linen fabrics, etc.	130	90	60	40	30	25
Jeans, cord, loden, cloth, knitted fabrics, etc.	180	140	120	100	80	60
Viscose, satin, chiffon, organza, taffeta, etc.	140	100	80	60	50	40
LYCRA®, neoprene, etc.	120	80	50	40	35	30
Artificial fur, artificial leather, fleece, suede, etc.	200	150	120	90	70	50

Pressure: high  
Aids: Teflon®, pressing cloth

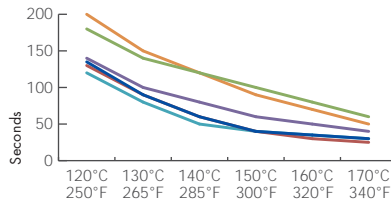

### APPLICATION FROM THE BACK



	Temperature/time required (in seconds)					
	120 °C	130 °C	140 °C	150 °C	160 °C	170 °C
	250 °F	265 °F	285 °F	300 °F	320 °F	340 °F

Reference fabric	60	45	30	25	20	15
Silk, batiste, cotton jersey, thin linen fabrics, etc.	35	28	22	18	15	12
Jeans, cord, loden, cloth, knitted fabrics, etc.	60	45	35	30	25	20
Viscose, satin, chiffon, organza, taffeta, etc.	30	25	20	15	12	10
LYCRA®, neoprene, etc.	55	40	30	25	20	15
Artificial fur, artificial leather, fleece, suede, etc.	70	55	45	40	35	30

Pressure: high  
Aids: Teflon®, pressing cloth, transfer film to fix in place

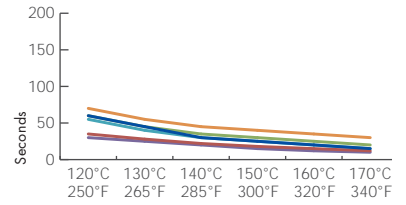

# HOTFIX SELECTOR 10

## CRYSTAL MESH XL

### APPLICATION FROM THE FRONT



	Temperature/time required (in seconds)					
	120 °C	130 °C	140 °C	150 °C	160 °C	170 °C
	250 °F	265 °F	285 °F	300 °F	320 °F	340 °F

Reference fabric	-	-	90	60	50	40
Silk, batiste, cotton jersey, thin linen fabrics, etc.	-	-	75	50	35	30
Jeans, cord, loden, cloth, knitted fabrics, etc.	-	-	190	150	100	80
Viscose, satin, chiffon, organza, taffeta, etc.	-	-	100	70	60	50
LYCRA®, neoprene, etc.	-	-	80	60	50	40
Artificial fur, artificial leather, fleece, suede, etc.	-	-	140	100	80	60

Pressure: high  
Aids: Teflon®, pressing cloth

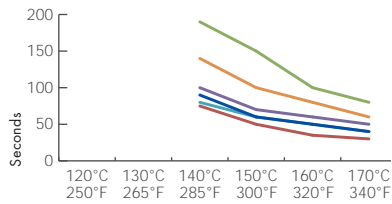

### APPLICATION FROM THE BACK



	Temperature/time required (in seconds)					
	120 °C	130 °C	140 °C	150 °C	160 °C	170 °C
	250 °F	265 °F	285 °F	300 °F	320 °F	340 °F

Reference fabric	60	45	30	25	20	15
Silk, batiste, cotton jersey, thin linen fabrics, etc.	35	28	22	18	15	12
Jeans, cord, loden, cloth, knitted fabrics, etc.	60	45	35	30	25	20
Viscose, satin, chiffon, organza, taffeta, etc.	30	25	20	15	12	10
LYCRA®, neoprene, etc.	55	40	30	25	20	15
Artificial fur, artificial leather, fleece, suede, etc.	70	55	45	40	35	30

Pressure: high  
Aids: Teflon®, pressing cloth

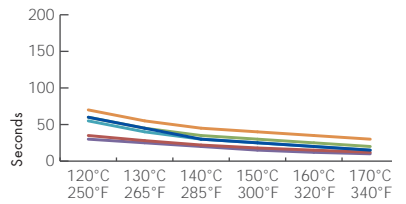

# HOTFIX SELECTOR 11

## FRAMED FLAT BACK

### APPLICATION FROM THE FRONT



	Temperature/time required (in seconds)					
	120 °C	130 °C	140 °C	150 °C	160 °C	170 °C
	250 °F	265 °F	285 °F	300 °F	320 °F	340 °F
Reference fabric	95	80	65	50	45	40
Silk, batiste, cotton jersey, thin linen fabrics, etc.	90	75	60	47	40	35
Jeans, cord, loden, cloth, knitted fabrics, etc.	95	80	65	50	45	40
Viscose, satin, chiffon, organza, taffeta, etc.	90	75	60	47	40	35
LYCRA®, neoprene, etc.	80	65	55	47	40	35
Artificial fur, artificial leather, fleece, suede, etc.	100	88	70	57	50	40

Pressure: low  
Aids: Teflon®, pressing cloth, silicone foam

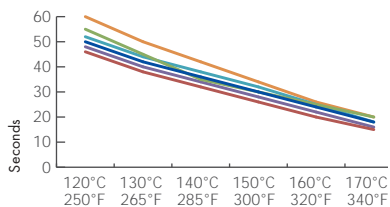

### APPLICATION FROM THE BACK



	Temperature/time required (in seconds)					
	120 °C	130 °C	140 °C	150 °C	160 °C	170 °C
	250 °F	265 °F	285 °F	300 °F	320 °F	340 °F
Reference fabric	20	17	14	11	8	6
Silk, batiste, cotton jersey, thin linen fabrics, etc.	15	13	11	9	7	5
Jeans, cord, loden, cloth, knitted fabrics, etc.	25	23	21	18	15	12
Viscose, satin, chiffon, organza, taffeta, etc.	12	10	8	7	6	5
LYCRA®, neoprene, etc.	35	30	25	18	13	8
Artificial fur, artificial leather, fleece, suede, etc.	50	40	35	30	25	20

Pressure: low  
Aids: Teflon®, pressing cloth, silicone foam

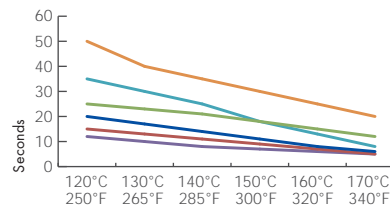





## **SEWING, EMBROIDERY, AND HAND APPLICATION**

There are many Swarovski products that are suitable for sewing and embroidering. These products can be easily applied either by hand, or with standard domestic or industrial sewing and embroidery machines. Swarovski also offers an ideal selection of products for a variety of creative techniques by hand.

## PRODUCT OVERVIEW

The following products are suitable for sewing (by hand or machine), embroidery or hand application (e.g. beading):

	SEWING	EMBROIDERY	HAND APPLICATION TECHNIQUES
Settings	✓ <sup>1</sup>		✓
Beads	✓ <sup>1</sup>		✓
BeCharmed & Pavé	✓ <sup>1</sup>		✓
Crystal Pearls	✓ <sup>1</sup>		✓
Pendants	✓ <sup>1</sup>		✓
Sew-on Articles	✓	✓ <sup>2</sup>	✓
Synthetics Hoffix: Crystaltex	✓ <sup>3</sup>		
Plastic Trimmings	✓	✓ <sup>4</sup>	✓ <sup>5</sup>
Crystal Buttons & Buttons with Plastic / Metal Shank	✓		✓
Zippers	✓		
Metal Trimmings: Chaton & Flat Back Bandings	✓		
Metal Trimmings: Spike Bandings	✓ <sup>1</sup>		
Metal Trimmings: Roses & Chaton Montées	✓ <sup>1</sup>		✓
Crystal Mesh	✓ <sup>6</sup>		
Cupchains & Findings	✓		✓

1 These products should be sewn by hand.

2 Lochrose art. 3129

3 Not suitable for Crystaltex Chaton Bandings

4 Art. 50 002, 50 003 and 50 004 (single-row)

5 Plastic Components like Mini Rondelles

6 Crystal Fine Mesh has a very tight structure and should therefore be sewn by hand.

## MACHINES, TOOLS, AND AIDS

The following machines, tools, and aids can be used for sewing and embroidering Swarovski products:



A **household sewing machine** offers a range of stitch types such as straight stitch, zigzag stitch and a program for sewing on buttons, and is therefore well suited to applying Swarovski products.



An **industrial sewing machine** is suitable for most sewing applications. However, a machine with a zigzag stitching program is necessary for some Swarovski products.



A **button sewer** can also be used for the application of some Swarovski Buttons.





Various **fully automatic embroidery machines** can be used for application, depending on the product.



The **lock stitch head** is ideal for applying single-row Plastic Trimmings.



Use a device like the **Laesser Crystal Stone Head** for Schifflli embroidery machines (or the **Lochrose Embroidery Device** from Tajima) to fully automatically apply Lochrose art. 3129.



**Embroidery interfacing** stabilizes the fabric.



**Spray glue** is used to fix the fabric on the interfacing.



A **frame** serves to stabilize thin and elastic fabrics during industrial embroidery processes.



**Adapted presser feet/beading feet** (e.g. for single-row Plastic Trimmings): standard presser feet, adapted by adding two metal plates.



By gluing on **small metal plates** (offered by Swarovski), an adapted presser foot can be made.



For zippers and products with net-edge, a **zipper foot** is helpful. A **button foot** can be used for the application of Crystal Buttons and Sew-on Articles.

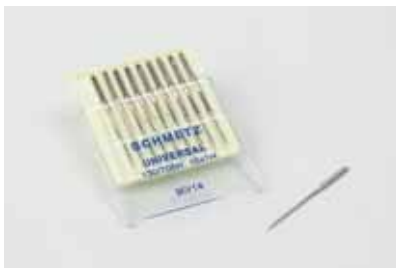

**Sewing and embroidery machine needles** sizes Nm 70-100.



**Sewing thread** (Nm 50 - 80); stronger synthetic thread is more suitable for sewing on items.



It is recommended that **protective eyewear** is worn when using a sewing machine, so as to prevent injury.

### Adapted presser foot

To adapt a sewing machine's standard presser foot (e.g. for sewing Plastic Trimmings on garments), affix two small plates to the underside of the presser foot with help of epoxy adhesive. Make sure that the plates are tailored to the height of the Swarovski product. When gluing, also be aware of the recommended width.

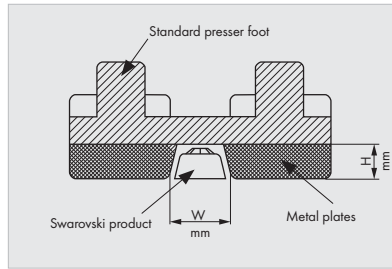
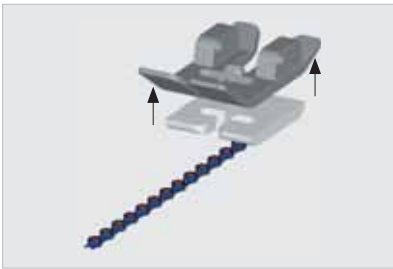

The **metal plates** are glued to the left and right side of the standard presser foot.

### Adapted presser foot

### Available metal plates from Swarovski

Plastic Trimmings	Width	Height	Metal plates
Art. 50 002	2.7 mm	2.3 mm	Art. 9040/055
Art. 50 003	3.4 mm	2.5 mm	Art. 9040/056
Art. 50 004	4.4 mm	3.5 mm	Art. 9040/057

## SUPPLIERS

This list provides an overview of selected suppliers worldwide.

MACHINES / TOOLS / AIDS	SUPPLIER	CONTACT
Sewing machines	Elna International Corp. AG	<a href="http://www.elna.com">www.elna.com</a>
	Pfaff	<a href="http://www.pfaff.com">www.pfaff.com</a>
Button sewer	Pfaff	<a href="http://www.pfaff.com">www.pfaff.com</a>
Industrial embroidery machines (for Plastic Trimmings)	Barudan America, Inc.	<a href="http://www.barudan.com">www.barudan.com</a>
	MECA Srl	<a href="http://www.meca.it">www.meca.it</a>
	Tajima Industries Ltd.	<a href="http://www.tajima.com">www.tajima.com</a>
	ZSK GmbH	<a href="http://www.zsk.de">www.zsk.de</a>
Embroidery device for Lochrose art. 3129	Laesser AG	<a href="http://www.laesser.ch">www.laesser.ch</a>
	Crystal Stone Head for Laesser embroidery machines  Tajima Industries Ltd. Lochrose Embroidery Device	<a href="http://www.tajima.com">www.tajima.com</a>
Adapted presser foot / beading foot for sewing Plastic Trimmings	Elna International Corp. AG Pearl / Bead Foot	<a href="http://www.elna.com">www.elna.com</a>
	Pfaff Beading Foot	<a href="http://www.pfaff.com">www.pfaff.com</a>
Metal plates for adapting a presser foot	Swarovski: For Plastic Trimming art. 50 002: art. 9040/055	<a href="http://www.swarovski.com/professional">www.swarovski.com/professional</a>
	For Plastic Trimming art. 50 003: art. 9040/056	
	For Plastic Trimming art. 50 004: art. 9040/057	
Machine needles	Ferd. SCHMETZ GmbH	<a href="http://www.schmetz.com">www.schmetz.com</a>
	Groz-Beckert KG	<a href="http://www.groz-beckert.de">www.groz-beckert.de</a>
	Prym	<a href="http://www.prym-consumer.com">www.prym-consumer.com</a>
Sewing threads	AMANN & Soehne GmbH & Co. KG	<a href="http://www.amann.com">www.amann.com</a>
	Coats PLC	<a href="http://www.coats.com">www.coats.com</a>
	MADEIRA Garnfabrik KG	<a href="http://www.madeira.de">www.madeira.de</a>
	RAYHER HOBBY GmbH	<a href="http://www.rayher-hobby.de">www.rayher-hobby.de</a>

## APPLICATION



When sewing Swarovski products, particularly Sew-on Articles, Crystal Buttons and Beads, **synthetic multifilament threads with a thread count of Nm 50 – 80** are most suitable. Monofilament and pure cotton yarns are not recommended due to their limited abrasion resistance.



In general, Swarovski products can be sewn on using a variety of stitch types.

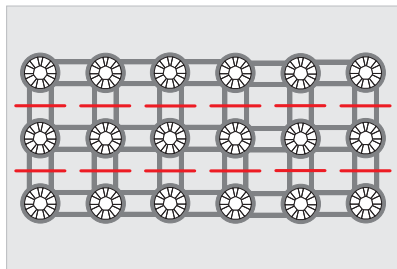

**Multi-row products**  
Straight stitch

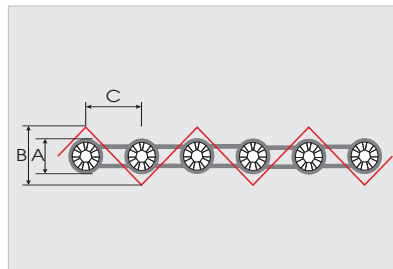

**Single-row products**  
Zigzag stitch

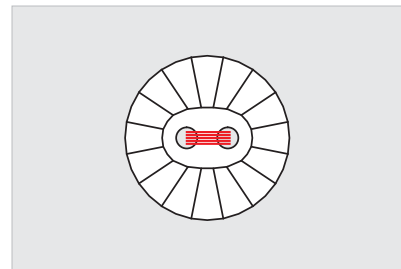

**Crystal Buttons and Sew-on Articles**  
Button sewing program or zigzag stitch

### Straight stitch

A stitch length should be selected that allows the stitches to fall in the spaces between the cups.

### Zigzag stitch

The length and width of the stitch must be adjusted to suit the element being applied. The width of the stitch (B) should be 0.5 mm – 1 mm broader on both sides than the crystal product (A) being applied. The length of the stitch (C) should be equal to about 2/3 of the width of the stitch. In some cases the tension of the upper thread must be reduced.

When applying products using a zigzag stitch, the use of an adapted presser foot is recommended.



### Button sewing program

Crystal Buttons and Sew-on Articles can be applied using a button sewing program. The hole spacing must be selected in order to use the program.

SELECTING THE OPTIMUM THREAD    SELECTING THE STITCH TYPE    **ADJUSTING THE UPPER THREAD TENSION**    APPLICATION

If the upper thread tension is too tight or too loose, the resulting seam is not strong. The tension of the thread must therefore be adjusted accordingly.

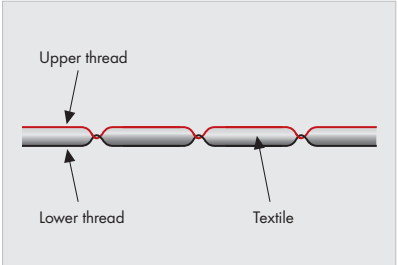

If the **tension is correct**, the threads cross in the middle of the textile.

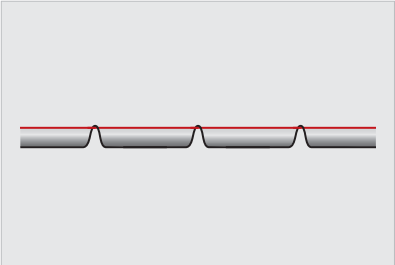

If the **tension is too tight**, the lower thread is visible on the upper surface of the fabric and the fabric can become gathered.

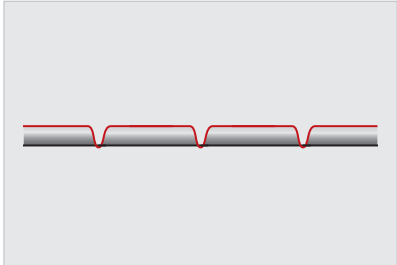

If the **tension is too loose**, the crossing of the threads is visible on the upper surface of the fabric.

SELECTING  
THE OPTIMUM THREAD

SELECTING  
THE STITCH TYPE

ADJUSTING THE UPPER  
THREAD TENSION

APPLICATION

Alongside sewing by hand, the following table provides a summary of possible machine application techniques.

### Machine application

SWAROVSKI PRODUCTS		MACHINE	TOOL/AID	PROGRAM	NOTE
<b>Sew-on Articles</b>	Sew-on Stones	Sewing machine	Button foot	Button sewing program or zigzag stitch without feed function	Switch off the lower feed, adjust the stitch width to the product. The use of the application aid in some types of sewing machines can require some readjustment of the tension release
	Lochrose art. 3129	Schiffli embroidery machine	Laesser Crystal Stone Head or Tajima Lochrose Embroidery Device		
<b>Synthetics Hotfix</b>	Crystaltex	Sewing machine	Standard presser foot	Straight stitch, zigzag stitch (single-row)	
<b>Plastic Trimmings</b>	Basic Bandings (single-row)	Sewing machine	Adapted standard presser foot	Zigzag stitch	Adjust the stitch width to the product
			Zipper foot	Straight stitch	When working with the net-edge option of the Banding
	Basic Bandings (single-row)	Embroidery machine	Lock stitch head	Zigzag stitch	
	Basic Bandings (multi-row)	Sewing machine	Standard presser foot	Straight stitch, zigzag stitch	Adjust the stitch width to the product
			Zipper foot	Straight stitch	When working with the net-edge option of the Banding
	Fishnet Bandings	Sewing machine	Adapted standard presser foot	Straight stitch	
	Decorative Bandings	Sewing machine	Zipper foot	Straight stitch	When working with the net-edge option of the Banding
Special sewing machine			Special presser foot	Programmed stitch	
<b>Buttons, Fasteners &amp; Zippers</b>	Crystal Buttons	Sewing machine	Button foot	Button sewing program or zigzag stitch without feed function	Switch off the lower feed, adjust the stitch width to the product
		Button sewer		Button sewing program	Holding clamps must be adjusted to the shape of the button
	Buttons with Plastic Shank / Metal Shank	Button sewer		Button sewing program	Holding clamps must be adjusted to the shape of the button
	Zippers	Sewing machine	Zipper foot	Straight stitch	
<b>Metal Trimmings</b>	Chaton & Flat Back Bandings	Sewing machine	Standard presser foot	Straight stitch	
			Zipper foot	Straight stitch	When working with the net-edge option of the Banding
<b>Crystal Mesh</b>		Sewing machine	Standard presser foot	Straight stitch	Do not remove the transparent support film before sewing, but score the film along the course of the stitching beforehand
<b>Cupchains &amp; Findings</b>	Cupchains	Sewing machine	Adapted standard presser foot	Zigzag stitch	Adjust the stitch width to the product

### Application using a sewing machine

The right choice of needle (strength Nm 70 - 100), sewing thread and thread tension (upper and lower thread) are particularly important for applications with a sewing machine. The fabric must not become gathered and the upper and lower thread should run easily and smoothly.

Tests should be conducted on the original material before beginning production.

Before sewing on Crystal Buttons with a machine it is essential to set the sewing machine to the correct hole and stitch length, as well as stitch width. This prevents the crystal from being damaged during application and reduces the risk of injury.

When sewing high, multi-row products, there can be problems with the sewing machine feed, caused by a slanting presser foot. To avoid this, position a **height compensator** beneath the presser foot to ensure it sits parallel to the material, allowing the fabric to feed through properly.

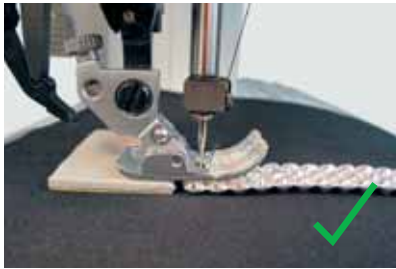

The foot lies flat due to the **height compensator**.



A slanting presser foot can cause problems with the feed of the base material.



#### Sew-on Stones

Switch off the lower feed and adjust the stitch width to the product.



#### Crystaltex Bandings

Sew between the rows of crystals.



#### Basic Bandings (single-row)

Make sure that the Basic Banding runs parallel to the foot.



#### Basic Bandings (multi-row)

Stitch the banding between the first and second rows of crystals and if necessary strengthen the corners with a zigzag stitch.



#### Fishnet Bandings

Adjust the needle bar so that the stitches are next to the crystals.



#### Crystal Buttons

Switch off the lower feed and adjust the stitch width to the product.



#### Zippers

It is possible to sew very close to the teeth of the zipper when using a zipper foot. In some cases, it can also be very helpful to adjust the needle bar.



**Chaton & Flat Back Bandings**

Stitch the Banding between the rows of crystals.



**Crystal Mesh**

Stitch the banding between the first and second rows of crystals. Alternatively, use a zigzag stitch.

Note: Consider the useful information about the support film on the pages 114 and 119.



**Cupchains**

Make sure that the Cupchain runs parallel to the foot.

**Application using a button sewer**

Amongst other Swarovski products, Crystal Buttons, Buttons with Plastic Shank and Buttons with Metal Shank can also be applied using a button sewer.

**CRYSTAL BUTTONS**

Before application, it is essential to set the button sewer according to the used Crystal Button. This prevents the product from being damaged during application and reduces the risk of injury.

**BUTTONS WITH PLASTIC SHANK AND BUTTONS WITH METAL SHANK**

Just like Crystal Buttons, Buttons with Plastic or Metal Shank can be easily affixed using a button sewer. To do this, they must be positioned in the application slot of the button holder, and the machine must be adjusted beforehand.





### Application using an embroidery machine

The industrial application of single-row Plastic Trimmings and Lochrose art. 3129 can be carried out on fully automatic embroidery machines.

#### PLASTIC TRIMMINGS



1 First design the motif. Choose the desired type of Plastic Trimming and the embroidery thread.

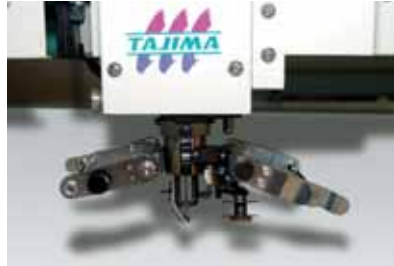

2 A lock stitch head can be used for applying Plastic Trimmings. It allows the Plastic Trimmings to be fixed to the carrier material by using zigzag stitch.



3 Wind the Plastic Trimming onto a suitable spool.



4 When spool and thread are in place, fix the fabric into place with spray glue.

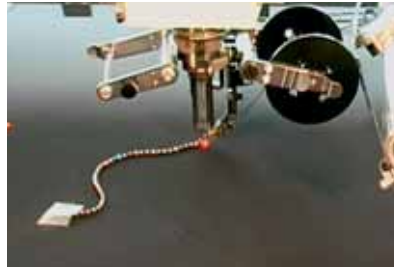

5 Start the stitching process.



6 The customized material is now ready for further processing.

A comprehensive video about working with Plastic Trimmings can be found on the Swarovski business website [SWAROVSKI.COM/PROFESSIONAL](http://SWAROVSKI.COM/PROFESSIONAL).

#### LOCHROSE art. 3129

An innovative product application solution has been developed in conjunction with the companies Laesser and Tajima for the industrial application of Lochrose art. 3129 with fully automatic embroidery machines. If using a Laesser embroidery machine, the Laesser Crystal Stone Head must be used. The application is based on standard embroidery technology and allows the unique combination of first-class Schiffl embroidery yarns (e.g. SETAFIL®) and crystal applications in a single production stage.

If sewing with a Tajima embroidery machine is preferred, the Tajima Lochrose Embroidery Device is used.



Orders for the **Lochrose art. 3129**, as well as sample and production orders, can be placed directly with your Swarovski sales partner.



1 Draw the desired motif.

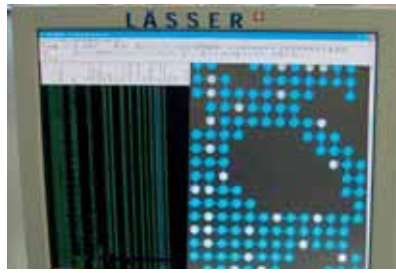

2 Enter the design into the embroidery software.



3 Fill the embroidery machine with Lochrose art. 3129.



4 Embroidery is carried out automatically using a system like the Laesser Crystal Stone Head (in the photo) or the Tajima Lochrose Embroidery Device.



5 The embroidered material is now ready for further processing.

Picture source:  
S. Jurkowitzsch

### Hand application techniques

Some of the Swarovski products listed in the product overview at the beginning of this chapter can be applied by hand. This means a range of creative application techniques in addition to sewing and embroidery.



Knitting

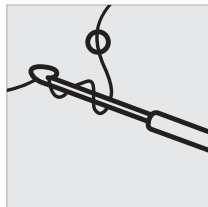

Crocheting

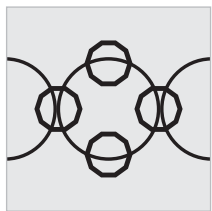

Beading

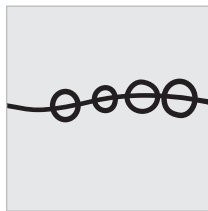

Threading

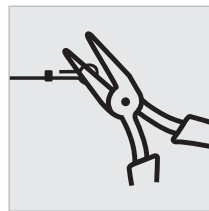

Wire working

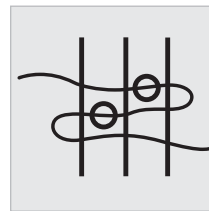

Weaving

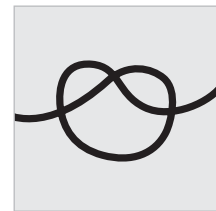

Knitting

Please choose a sufficiently thick wire in accordance to the size and weight of the Swarovski crystals. For heavier products a nylon-coated wire is recommended. Crystal Pearls larger than 6 mm should be additionally knotted for a better hold. Detailed instructions for these techniques and information concerning the necessary tools and aids required for the work are given on [WWW.CREATE-YOUR-STYLE.COM](http://WWW.CREATE-YOUR-STYLE.COM).

---

## USEFUL INFORMATION

### Cutting and sewing Crystal Mesh

Before cutting and sewing, the transparent film must not be removed. The film allows the individual crystals to be aligned perfectly, and provides Crystal Mesh with the stability necessary for flawless application.

In case the Crystal Mesh is fixed on the fabric with Hotfix prior to sewing, the foil can be removed before starting to sew.

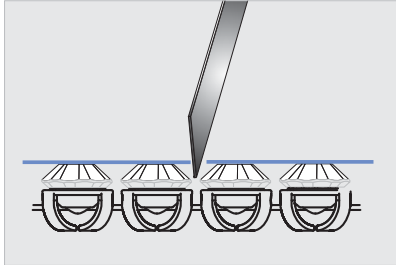

**Pre-scoring:** Score the transparent film between the rows of crystals with a Stanley knife, though do not pull them apart – otherwise the stability of the crystals during cutting and sewing will be lost.

**Cutting:** Cut the metal with scissors along the scored line, and remove the excess link rings. The Crystal Mesh is now ready for sewing.

**Sewing:** When sewing Crystal Mesh, it is recommended that the film is scored along the course of the stitching beforehand (see illustration).

**Note:** Crystal Fine Mesh cannot be sewed with a sewing machine due to its tight structure.

### Cutting Metal Trimmings

It is recommended that the frayed ends are removed using heat. This avoids the support fabric entering the cutting point and consequently reducing the rigidity of the product.

Alternatively, the cutting and removal can be carried out in a single process using a hot knife fabric cutter. After cutting the net the ends should be finished with flame (e.g. lighter) that the crystal cannot scale off the net.

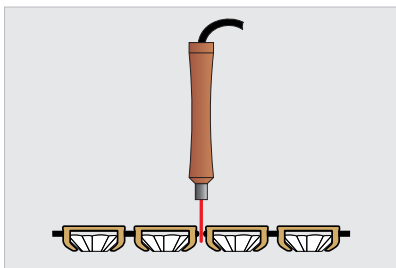

Cutting and removal of ends in a single process.

## QUICK ASSISTANCE

The following table outlines common problems and their causes when sewing, and offers advice on how to avoid them. Further details and more extensive descriptions can be found in the section marked with a **?!**

PROBLEM	CAUSE
Product or fabric is not fed through correctly.	1, 2, 3
The machine misses out stitches.	4, 5, 6, 7
The thread breaks.	4, 6, 8, 9
The needle breaks.	10, 11, 12, 13
The crystals break out of the cups.	14

CAUSE	RECOMMENDATION
1 The foot pressure may be too low.	Increase the foot pressure according to the instructions.
2 There may be dust between the feeder teeth.	Clean the feeder teeth.
3 Upper feed is faulty.	Replace the upper feed.
4 The needle may be bent or damaged.	Replace the needle.
5 The needle is not fitted correctly.	The needle must be pushed right up to the top.
6 The machine may be threaded wrongly.	Rethread the machine.
7 The tension of the threads may be incorrect.	Check the thread tension.
8 There may be knots in the thread or it may be too thin.	Check the thread for faults and if necessary, change it.
9 The components that form the stitches may be damaged.	Have the sewing machine checked by a specialist.
10 The wrong needle may have been chosen.	Choose a needle that has the correct size for the carrier material.
11 The bobbin may not be fitted correctly.	Check the bobbin case.
12 The needle is too thick and gets stuck in the product.	Use a thinner needle.
13 The needle hits the crystal.	Sew more slowly and feed the product through the machine more carefully.
14 The needle damages the cup.	Check the length of the stitch and the thickness of the needle.





## **MECHANICAL** APPLICATION

Many Swarovski products, such as Snap Fasteners, Rivets, and Rose Pins can be applied manually or mechanically, using either semi- or fully-automated machines.

This simple application technique is used primarily in the textile and accessories fields.

## PRODUCT OVERVIEW

The following products are suitable for mechanical application:

BUTTONS, FASTENERS & ZIPPERS	MECHANICAL APPLICATION
Snap Fasteners, Decorative Buttons, Inset Snap Fasteners, and XIRIUS Flat Back Snap Fasteners	✓
Jeans Buttons	✓

METAL TRIMMINGS	MECHANICAL APPLICATION
Rivets, Crystal Pearl Rivets, Square Rivets, Chessboard Rivets, Star Rivets, and Spike Rivets	✓
Rose Pins, Chessboard Pins, and Rhombus Pins	✓
Crystal Studs	✓

## MACHINES, TOOLS, AND AIDS

The following machines, tools, and aids can be used for the mechanical application of Swarovski products:



The **fly press** (art. 9040/019, with mounting board) represents an easy way to mechanically apply the products.



For the application of various products, such as Rivets, Rose Pins, Crystal Studs, Decorative Buttons and Snap Fasteners, a **hand tool** can be used. Please be advised that Swarovski does not provide the necessary tools.



Some Swarovski products can be applied using a semi- or fully-**automatic attaching machine** (e.g. Rose Pins). In this process, the feed on the machine must be adjusted to the product being processed.



**Vacuum pump** with silicone hose allows Rivets and Pins to be easily held in place for the fly press (art. 9040/022).



It is recommended that **protective eyewear** is worn during mechanical application, to prevent injury.



Swarovski offers a variety of different tools for the fly press, depending on the product employed. The tools offered have the following specifications: upper die (M6 screw thread), lower die (12,15 mm +0,03/- 0,10).  
 If using a fly press from a provider other than Swarovski, confirm the thread sizes before ordering the tools.

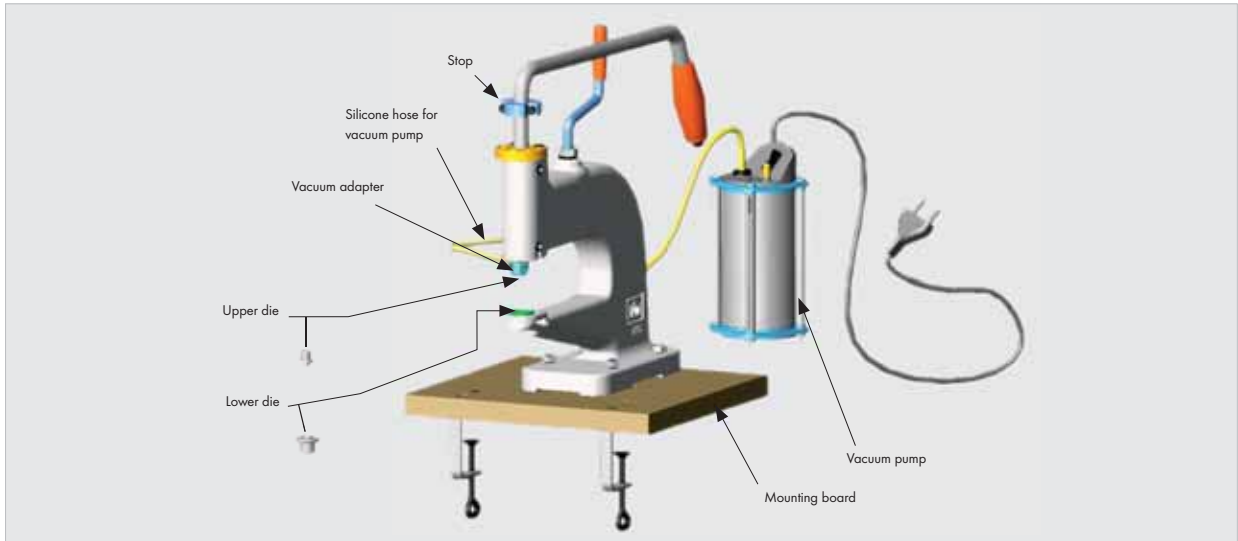

Fly press including possible dies and aids for application (in this case for the application of Rivets).

### Snap Fasteners and Decorative Buttons

#### 1780/100 Snap Fastener



	Parts	Upper Die	Lower Die
	<p>Female</p>	<p>Art. 9060/005</p>	<p>Art. 9060/004</p>
<p>Male</p>	Required Application Tools	<p>Art. 9060/006</p>	<p>Art. 9060/007</p>

#### 1780/114 Snap Fastener

	Parts	Upper Die	Lower Die
	<p>Female</p>	<p>Art. 9060/005</p>	<p>Art. 9060/004</p>
<p>Male</p>	Required Application Tools	<p>Art. 9060/006</p>	<p>Art. 9060/007</p>

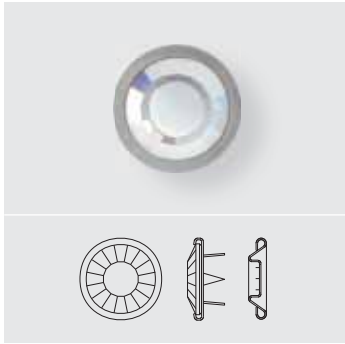

### 1781/100 Decorative Button



Parts	Required Application Tools	
Upper Die	Lower Die	
		
Female	Art. 9060/005	Art. 9060/004

### 1781/114 Decorative Button



Parts	Required Application Tools	
Upper Die	Lower Die	
		
Female	Art. 9060/005	Art. 9060/004

## Inset Snap Fasteners

### 1782/190 Inset Snap Fastener



Parts	Required Pre-Punch Tools		Required Application Tools	
Female	Upper Die	Lower Die	Upper Die	Lower Die
				
Male	Art. 9060/022 (M6)	Art. 9060/023	Art. 9060/024 (M6)	Art. 9060/025 Art. 9060/026

Tools for the Inset Snap Fastener are also available as a set: art. 9060/021.

### XIRIUS Flat Back Snap Fastener

The XIRIUS Flat Back Snap Fastener is applied using a fly press. The product consists of two parts: the decorative (upper) part and the closure (lower) part. For the application with a fly press, both parts need a specific upper and a lower die.

A vacuum pump (art. 9040/022) and a vacuum adapter (art. 9040/105) enable an easy fixation of the products in the upper die during application.



**Vacuum adapter** (art. 9040/105) with external screw instead of inner thread to fix the upper die (art. 9060/032 and art. 9060/034).

### 1783/300 01 XIRIUS Flat Back Snap Fastener

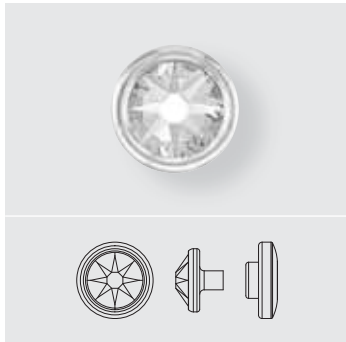

Parts	Required Application Tools			
	Upper Die	Vacuum Adapter	Spare Part*	Lower Die
Female				
	Art. 9060/032	Art. 9040/105	Art. 9060/036	Art. 9060/033

### 1783/300 02 XIRIUS Flat Back Snap Fastener

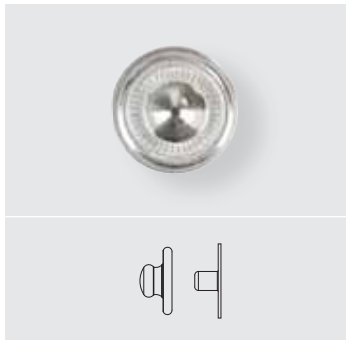

Parts	Required Application Tools		
	Upper Die	Vacuum Adapter	Lower Die
Male			
	Art. 9060/034	Art. 9040/105	Art. 9060/035

\* The spare part (plastic insert) is integrated into the upper die as standard. It should be changed when it becomes worn.



## Jeans Buttons

### 1790/100 Jeans Button

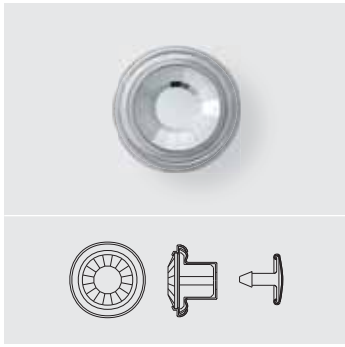

Parts	Upper Die <sup>3</sup>	Lower Die	Thread Adapter
<p>Female</p>	<p>Art. 9060/001</p>	<p>Art. 9060/016</p>	<p>Art. 9060/014 (M6)<sup>2</sup></p>

### 1790/104 Jeans Button



Parts	Upper Die <sup>3</sup>	Spare Part <sup>4</sup>	Lower Die	Thread Adapter	Changing Pin
<p>Female</p>	<p>Art. 9060/009<sup>1</sup></p>	<p>Art. 9060/011</p>	<p>Art. 9060/016</p>	<p>Art. 9060/014 (M6)<sup>2</sup></p>	<p>Art. 9060/015</p>
Tool Set					
					Art. 9060/020

### 1790/114 Jeans Button



Parts	Upper Die <sup>3</sup>	Lower Die	Thread Adapter
<p>Female</p>	<p>Art. 9060/001</p>	<p>Art. 9060/016</p>	<p>Art. 9060/014 (M6)<sup>2</sup></p>

### 1790/140 Jeans Button



Parts	Upper Die <sup>3</sup>	Spare Part <sup>4</sup>	Lower Die	Thread Adapter	Changing Pin
<p>Female</p>	<p>Art. 9060/009<sup>1</sup></p>	<p>Art. 9060/010</p>	<p>Art. 9060/016</p>	<p>Art. 9060/014 (M6)<sup>2</sup></p>	<p>Art. 9060/015</p>
Tool Set					
					Art. 9060/020

- 1 The plastic insert for the upper die (art. 9060/009) must be ordered separately depending on the type of button it will be used with.
- 2 The appropriate thread adapter is supplied with the fly press art. 9040/017 and art. 9040/019.
- 3 Holder for Insert
- 4 Insert for Upper Die

### 1791/120 Jeans Button

	Parts		Upper Die <sup>3</sup>	Spare Part <sup>4</sup>	Lower Die	Thread Adapter	Changing Pin
	Female		<b>Required Application Tools</b>	 Art. 9060/009 <sup>1</sup>	 Art. 9060/012	 Art. 9060/016	 Art. 9060/014 (M6) <sup>2</sup>
<b>Tool Set</b>							
 Art. 9060/020							

### 1792/100 Jeans Button

	Parts		Upper Die <sup>3</sup>	Spare Part <sup>4</sup>	Lower Die	Thread Adapter	Changing Pin
	Female		<b>Required Application Tools</b>	 Art. 9060/009 <sup>1</sup>	 Art. 9060/013	 Art. 9060/016	 Art. 9060/014 (M6) <sup>2</sup>
<b>Tool Set</b>							
 Art. 9060/020							

### 1795/140 Jeans Button

	Parts		Upper Die <sup>3</sup>	Spare Part <sup>4</sup>	Lower Die	Thread Adapter	Changing Pin
	Female		<b>Required Application Tools</b>	 Art. 9060/009 <sup>1</sup>	 Art. 9060/018	 Art. 9060/016	 Art. 9060/014 (M6) <sup>2</sup>
<b>Tool Set</b>							
 Art. 9060/020							

### 1796/140 Jeans Button

	Parts		Upper Die <sup>3</sup>	Spare Part <sup>4</sup>	Lower Die	Thread Adapter	Changing Pin
	Female		<b>Required Application Tools</b>	 Art. 9060/009 <sup>1</sup>	 Art. 9060/018	 Art. 9060/016	 Art. 9060/014 (M6) <sup>2</sup>
<b>Tool Set</b>							
 Art. 9060/020							

1 The plastic insert for the upper die (art. 9060/009) must be ordered separately depending on the type of button it will be used with.  
 2 The appropriate thread adapter is supplied with the fly press art. 9040/017 and art. 9040/019.  
 3 Holder for Insert  
 4 Insert for Upper Die

## 1791/120 Jeans Button



Parts	Upper Die <sup>3</sup>	Spare Part <sup>4</sup>	Lower Die	Thread Adapter	Changing Pin
 <p>Female</p>	 Art. 9060/009 <sup>1</sup>	 Art. 9060/012	 Art. 9060/016	 Art. 9060/014 (M6) <sup>2</sup>	 Art. 9060/015
	Tool Set  Art. 9060/020				

Required Application Tools

1 The plastic insert for the upper die (art. 9060/009) must be ordered separately depending on the type of button it will be used with.  
 2 The appropriate thread adapter is supplied with the fly press art. 9040/017 and art. 9040/019.  
 3 Holder for Insert  
 4 Insert for Upper Die

## Rivets

Rivets can be applied to various materials with or without Back Parts. The correct die combination must be chosen accordingly. Please ensure that the recommended fabric strengths, listed in the "Application" subsection (page 141), are followed.

A vacuum pump and adapter allow Rivets and Crystal Pearl Rivets to be easily picked up and applied. Upper dies are thus available with different thread strengths. When using the Swarovski vacuum adapter, dies with an M8 thread are required. Alternatively, dies with M6 threads are available for presses from other manufacturers, or when not using a vacuum adapter. ?!

Required Application Tools	Upper die	Vacuum Adapter	Spare part for upper die (insert) <sup>1</sup>	Lower die for application with Back Part:	Lower die for application with Back Part:	Lower die for application without Back Part for Rivet Casing 088 Stainless Steel	Lower die for application without Back Part for Rivet Casing 081 Gold 082 Silver 086 Gun Metal 093 Rose Gold

### 53 000



Art. 9040/005 M8	Art. 9040/023	Art. 9040/008
Art. 9040/014 M6 <sup>2</sup>	-	

### 53 001



Art. 9070/005 M8	Art. 9040/023	Art. 9070/008
Art. 9070/009 M6	-	

### 53 002

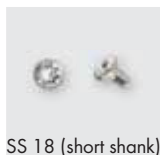

Art. 9040/005 M8	Art. 9040/023	Art. 9040/008
Art. 9040/014 M6 <sup>2</sup>	-	

### 53 005

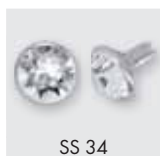

Art. 9040/064 M8	Art. 9040/023	Art. 9040/062
Art. 9040/063 M6	-	

### 53 006

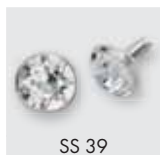

Art. 9040/067 M8	Art. 9040/023	Art. 9040/065
Art. 9040/066 M6	-	

### 53 008

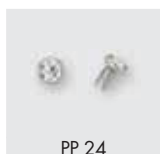











Art. 9040/083 M8	Art. 9040/023	Art. 9040/084
Art. 9040/085 M6	-	

<sup>1</sup> The spare part (plastic insert) is incorporated into the upper die as standard. It should be changed when it becomes worn.

<sup>2</sup> Tools with no Adapter (e.g. 9040/014 M6) can be screwed directly in a fly press directly. The fly press therefore must have the option of a vacuum directly through the shaft.

Required Application Tools

Upper die	Vacuum Adapter	Spare part for upper die (insert) <sup>1</sup>	Lower die for application with Back Part:	Lower die for application with Back Part:	Lower die for application without Back Part for Rivet Casing 088 Stainless Steel	Lower die for application without Back Part for Rivet Casing 081 Gold 082 Silver 086 Gun Metal 093 Rose Gold
			 53 007	 53 009		
			 Art. 9070/010	 Art. 9070/012	 Art. 9070/011	 Art. 9040/015

**53 400**

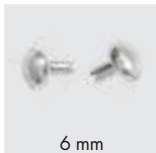

Art. 9040/068 M8	Art. 9040/023	Art. 9040/074
Art. 9040/071 M6	-	

**53 401**



Art. 9040/069 M8	Art. 9040/023	Art. 9040/075
Art. 9040/079 M6	-	

**53 402**



Art. 9040/070 M8	Art. 9040/023	Art. 9040/076
Art. 9040/073 M6	-	

**53 500**



Art. 9040/106	Art. 9040/105	-
---------------	---------------	---

**53 501**



Art. 9040/107	Art. 9040/105	-
---------------	---------------	---

**53 502**



Art. 9040/108	Art. 9040/105	-
---------------	---------------	---

**53 600**







Art. 9040/110 M8	Art. 9040/023	Art. 9040/111
Art. 9040/109 M6	-	

■	■					■
■	■					■
■	■					■
■	■	■	■	■		■
■	■					■
■	■					■
■	■					■

1 The spare part (plastic insert) is incorporated into the upper die as standard. It should be changed when it becomes worn.  
 2 Tools with no Adapter (e.g. 9040/014 M6) can be screwed directly in a fly press directly. The fly press therefore must have the option of a vacuum directly through the shaft.



Required Application Tools	Upper die	Vacuum Adapter	Spare part for upper die (insert) <sup>1</sup>	Lower die for application with Back Part:	Lower die for application with Back Part:	Lower die for application without Back Part for Rivet Casing 088 Stainless Steel	Lower die for application without Back Part for Rivet Casing 081 Gold 082 Silver 086 Gun Metal 093 Rose Gold
							
							

**53 700**



Art. 9040/112	Art. 9040/105	Art. 9040/113
---------------	---------------	---------------

**53 010**



Art. 9040/123	Art. 9040/105	Art. 9040/124
---------------	---------------	---------------

**53 011**

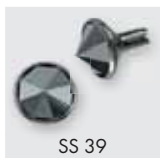

Art. 9040/125	Art. 9040/105	Art. 9040/126
---------------	---------------	---------------

**53 503**

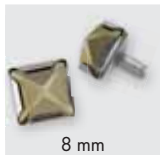

Art. 9040/127	Art. 9040/105	Art. 9040/128
---------------	---------------	---------------

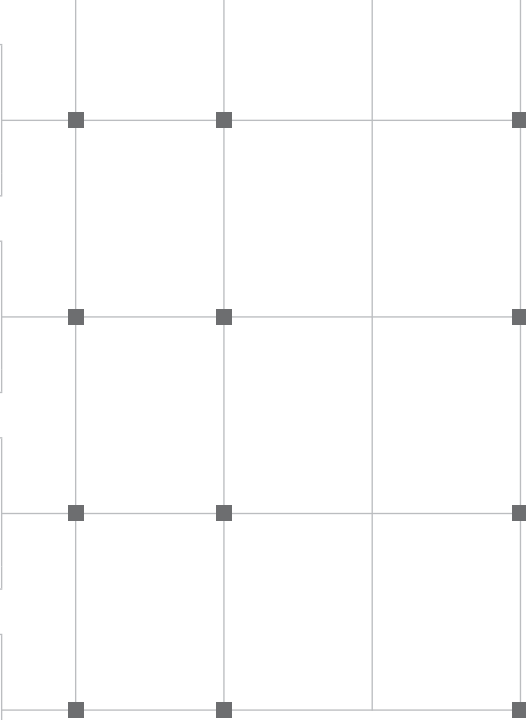







<sup>1</sup> The spare part (plastic insert) is incorporated into the upper die as standard. It should be changed when it becomes worn.

<sup>2</sup> Tools with no Adapter (e.g. 9040/014 M6) can be screwed directly in a fly press directly. The fly press therefore must have the option of a vacuum directly through the shaft.

## Rivet Flat Shaft

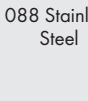
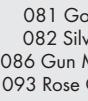
The **Rivet Flat Shaft**, available in stone size SS 29, presents a new addition to the existing assortment. It's easy to apply and no back part is needed, which not only reduces the distance between fabric and rivet but also ensures a flat surface on the back side.

Required Application Tools	Upper die	Vacuum Adapter	Spare part for upper die (insert) <sup>1</sup>	Lower die for application with Back Part: 53 007	Lower die for application with Back Part: 53 009	Lower die for application without Back Part for Rivet Casing 088 Stainless Steel	Lower die for application without Back Part for Rivet Casing 081 Gold 082 Silver 086 Gun Metal 093 Rose Gold
							
				Art. 9070/010	Art. 9070/012	Art. 9070/011	Art. 9040/015

### 53 003



Art. 9070/005 M8	Art. 9040/023	Art. 9070/008	2
-	-		

No back part is necessary for the application of the Rivet Flat Shaft. The big advantage of this Rivet is the possibility of applying it with an automatic attaching machine.

Please note: Lower die (art. 9070/010) was updated in autumn 2014. The new version can be used for all Rivet applications the former tool version was used for. However, please consider that for new Rivets such as the Rivet Flat Shaft, only the optimized version of the tool can be used. If a lower die with article number 9070/010 was bought before October 2014 the tool must be replaced in order to apply the Rivet Flat Shaft successfully.

A vacuum pump and a specially developed vacuum adapter (art. 9040/023) enable easy intake and application of the Rivet Flat Shaft. Generally, it is recommended to apply this Rivet only on non-elastic fabrics like jeans or leather with a material thickness of 2 - 3.5 mm.



**Vacuum adapter** with M6 outer thread for fixing to the fly press and M8 inner thread to hold the upper die (art. 9040/023).



Specially developed **vacuum adapter** with external screw instead of thread to fix the upper die (art. 9040/105).







<sup>1</sup> The spare part (plastic insert) is incorporated into the upper die as standard. It should be changed when it becomes worn.

<sup>2</sup> 53 003 is designed for ring rolling application and is self-backing. The rivet can be proceed on automatic and semi-automatic machines as well as with a fly press and therefore use lower die 9070/010 without any back part (53 007).

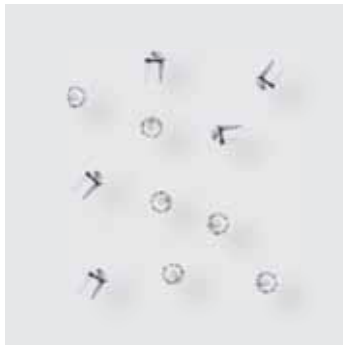



## Rose Pins

A vacuum pump allows Rose Pins to be easily picked up and applied. The vacuum connection is integrated directly into the upper die. An additional vacuum adapter is not necessary.





### 53 301 Rose Pins (SS 10)

	Part	Upper Die	Spare Part*	Lower Die	Centering aid
	 Female		 Art. 9040/090 M6	 Art. 9040/094	 Art. 9070/013

### 53 302 Rose Pins (SS 16)

	Part	Upper Die	Spare Part*	Lower Die
	 Female		 Art. 9040/091 M6	 Art. 9040/095

### 53 303 Rose Pins (SS 20)





	Part	Upper Die	Spare Part*	Lower Die
	 Female		 Art. 9040/092 M6	 Art. 9040/096

\* The spare part (plastic insert) is integrated into the upper die as standard. It should be changed when it becomes worn.

?!

## 53 304 Rose Pins (SS 34)



Part	Upper Die	Spare Part*	Lower Die
 Female	 Art. 9040/093 M6	 Art. 9040/097	 Art. 9070/016

\* The spare part (plastic insert) is integrated into the upper die as standard. It should be changed when it becomes worn.

?!



The **centering aid** for Rose Pins 53 301 (art. 9070/017) allows the product to be easily positioned in the upper die.

## Chessboard Pins and Rhombus Pins

Chessboard Pins and Rhombus Pins can be easily applied to various materials by using a fly press. A vacuum pump (art. 9040/022) and a vacuum adapter (art. 9040/105) enable an easy intake and application of the Pins.



Specially developed **vacuum adapter** (art. 9040/105) with external screw instead of thread to fix the upper die.

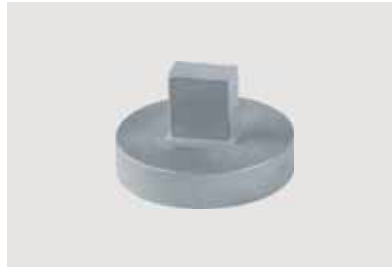

The **centering aid** for Rhombus Pins 53 320 (art. 9070/022) allows the product to be easily positioned in the upper die.

### 53 310 Chessboard Pin (6 mm)



Part	Upper Die	Vacuum Adapter	Spare Part	Lower Die	Centering aid
 Female	 Art. 9040/114	 Art. 9040/105	 Art. 9040/117	 Art. 9070/019	 Art. 9070/022

### 53 311 Chessboard Pin (10 mm)



Part	Upper Die	Vacuum Adapter	Spare Part	Lower Die	Centering aid
 Female	 Art. 9040/115	 Art. 9040/105	 Art. 9040/118	 Art. 9070/020	 Art. 9070/022

### 53 320 Rhombus Pin (10x6 mm)



Part	Upper Die	Vacuum Adapter	Spare Part	Lower Die	Centering aid
 Female	 Art. 9040/116	 Art. 9040/105	 Art. 9040/119	 Art. 9070/021	 Art. 9070/022

\* The spare part (plastic insert) is integrated into the upper die as standard. It should be changed when it becomes worn.



## Crystal Studs

A vacuum pump enables an easy intake and application of Crystal Studs. In the upper die the vacuum adapter is already integrated. Therefore, an additional adapter is not needed.

### 53 730 (PP 24 long shaft)



Parts	Upper Die	Lower Die	Buttonhole punching tool
 Female	 Art. 9040/120 M6	 Art. 9040/121	 Art. 9040/122

### 53 731 (PP 24 short shaft)

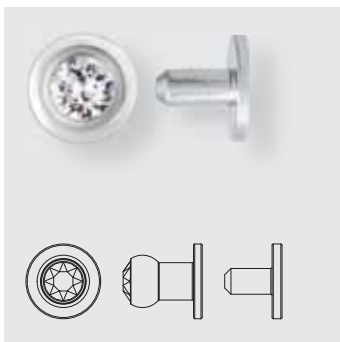

Parts	Upper Die	Lower Die	Buttonhole punching tool
 Female	 Art. 9040/120 M6	 Art. 9040/121	 Art. 9040/122



The **buttonhole punching tool** (art. 9040/122) can be used to create the buttonhole.

## SUPPLIERS

This list provides an overview of selected suppliers worldwide.

MACHINES / TOOLS / AIDS	SUPPLIER	CONTACT
Fly press	Swarovski: Fly press without mounting board: art. 9040/017 Fly press with mounting board: art. 9040/019 Jiuzhou Machinery Co., Ltd. Seung Min Industrial Co., Ltd. S.P.S. Tecnologia Meccanica Srl Standard Rivet Company	<a href="http://www.swarovski.com/professional">www.swarovski.com/professional</a>  <a href="http://www.sinojiuzhou.com">www.sinojiuzhou.com</a> <a href="http://www.seungminsm.co.kr">www.seungminsm.co.kr</a> <a href="http://www.spstecnologiameccanicasrl.it">www.spstecnologiameccanicasrl.it</a> <a href="http://www.standardrivet.com">www.standardrivet.com</a>
Tools for Snap Fasteners (fly press)	Swarovski: <b>Snap Fastener 1780/100 and 1780/114</b> Upper die: art. 9060/005 (1st stage) and art. 9060/006 (2nd stage) Lower die: art. 9060/004 (1st stage) and art. 9060/007 (2nd stage)	<a href="http://www.swarovski.com/professional">www.swarovski.com/professional</a>
Tools for Decorative Buttons (fly press)	Swarovski: <b>Decorative Buttons 1781/100 and 1781/114</b> Upper die: art. 9060/005 Lower die: art. 9060/004	<a href="http://www.swarovski.com/professional">www.swarovski.com/professional</a>
Tools for Inset Snap Fasteners (fly press)	Swarovski: <b>Inset Snap Fastener 1782/190</b> Pre-punch upper die: art. 9060/022 Pre-punch lower die: art. 9060/023 Upper die (M6) for Front Part and Back Part: art. 9060/024 Lower die for Front Part: art. 9060/025 Lower die for Back Part: art. 9060/026 All tools as set: art. 9060/021	<a href="http://www.swarovski.com/professional">www.swarovski.com/professional</a>
Tools for XIRIUS Flat Back Snap Fasteners (fly press)	Swarovski: <b>XIRIUS Flat Back Snap Fastener 1783/300</b> Vacuum adapter for upper dies: art. 9040/105 Upper die for decorative part (art. 1783/300 01): art. 9060/032 Spare part (plastic insert) for upper die (art. 9060/032): art. 9060/036 Lower die for decorative part (art. 1783/300 01): art. 9060/033  Upper die for closure part (art. 1783/300 02): art. 9060/034 Lower die for closure part (art. 1783/300 02): art. 9060/035	<a href="http://www.swarovski.com/professional">www.swarovski.com/professional</a>

MACHINES / TOOLS / AIDS	SUPPLIER	CONTACT
Tools for Jeans Buttons (fly press)	<p>Swarovski:</p> <p><b>Jeans Button 1790/100 and 1790/114</b></p> <p>Upper die: art. 9060/001 Lower die: art. 9060/016 Thread adapter (M6): art. 9060/014</p> <p><b>Jeans Button 1790/104</b></p> <p>Upper die: art. 9060/009 Spare part (plastic insert) for upper die: art. 9060/011 Lower die: art. 9060/016 Thread adapter (M6): art. 9060/014 Changing pin: art. 9060/015</p> <p><b>Jeans Button 1790/140</b></p> <p>Upper die: art. 9060/009 Spare part (plastic insert) for upper die: art. 9060/010 Lower die: art. 9060/016 Thread adapter (M6): art. 9060/014 Changing pin: art. 9060/015</p> <p><b>Jeans Button 1791/120</b></p> <p>Upper die: art. 9060/009 Spare part (plastic insert) for upper die: art. 9060/012 Lower die: art. 9060/016 Thread adapter (M6): art. 9060/014 Changing pin: art. 9060/015</p> <p><b>Jeans Button 1792/100</b></p> <p>Upper die: art. 9060/009 Spare part (plastic insert) for upper die: art. 9060/013 Lower die: art. 9060/016 Thread adapter (M6): art. 9060/014 Changing pin: art. 9060/015</p> <p><b>Crystal Fine Rocks Jeans Button 1795/140, Chessboard Buttons 1796/140 and Crystal Fabric Jeans Button 1797/140</b></p> <p>Upper die: art. 9060/009 Spare part (plastic insert) for upper die: art. 9060/018 Lower die: art. 9060/016 Thread adapter (M6): art. 9060/014 Changing pin: art. 9060/015</p> <p>All tools as set for <b>Jeans Buttons 1790/104, 1790/140, 1791/120, 1792/100, Crystal Fine Rocks Jeans Button 1795/140, Chessboard Buttons 1796/140 and Crystal Fabric Jeans Button 1797/140</b>: art. 9060/020</p>	<p><a href="http://www.swarovski.com/professional">www.swarovski.com/professional</a></p>



MACHINES / TOOLS / AIDS	SUPPLIER	CONTACT
Tools for Rivets (fly press)	<p>Swarovski:</p> <p><b>Rivet 53 000</b></p> <p>Upper die (M8): art. 9040/005</p> <p>Upper die (M6): art. 9040/014</p> <p>Spare part (plastic insert) for upper die (art. 9040/005 and 9040/014): art. 9040/008</p> <p>Lower die for Rivet application with Back Part 53 007: art. 9070/010</p> <p>Lower die for Rivet application with Back Part 53 009: art. 9070/012</p> <p>Lower die for Rivet application without Back Part (Rivet casing 081, 082 and 086): art. 9040/015</p> <p>Lower die for Rivet application without Back Part (Rivet casing 088): art. 9070/011</p> <p>Vacuum adapter for upper die: art. 9040/023</p> <p><b>Rivet 53 001</b></p> <p>Upper die (M8): art. 9070/005</p> <p>Upper die (M6): art. 9070/009</p> <p>Spare part (plastic insert) for upper die (art. 9070/005 and 9070/009): art. 9070/008</p> <p>Lower die for Rivet application with Back Part 53 007: art. 9070/010</p> <p>Lower die for Rivet application with Back Part 53 009: art. 9070/012</p> <p>Lower die for Rivet application without Back Part (Rivet casing 081, 082 and 086): art. 9040/015</p> <p>Lower die for Rivet application without Back Part (Rivet casing 088): art. 9070/011</p> <p>Vacuum adapter for upper die: art. 9040/023</p> <p><b>Rivet 53 002</b></p> <p>Upper die (M8): art. 9040/005</p> <p>Upper die (M6): art. 9040/014</p> <p>Spare part (plastic insert) for upper die (art. 9040/005 and 9040/014): art. 9040/008</p> <p>Lower die for Rivet application without Back Part (Rivet casing 081, 082 and 086): art. 9040/015</p> <p>Vacuum adapter for upper die: art. 9040/023</p> <p><b>Rivet 53 003</b></p> <p>Upper die (M8): art. 9070/005</p> <p>Spare part (plastic insert) for upper die (art. 9070/005): art. 9070/008</p> <p>Lower die for Rivet application without any Back Part (53 007): art. 9070/010</p> <p>Vacuum adapter for upper die: art. 9040/023</p>	<p><a href="http://www.swarovski.com/professional">www.swarovski.com/professional</a></p>

MACHINES / TOOLS / AIDS	SUPPLIER	CONTACT
(cont. from page 145)	<p><b>Rivet 53 005</b></p> <p>Upper die (M8): art. 9040/064</p> <p>Upper die (M6): art. 9040/063</p> <p>Spare part (plastic insert) for upper die (art. 9040/064 and 9040/063): art. 9040/062</p> <p>Lower die for Rivet application with Back Part 53 007: art. 9070/010</p> <p>Lower die for Rivet application with Back Part 53 009: art. 9070/012</p> <p>Lower die for Rivet application without Back Part (Rivet casing 081, 082 and 086): art. 9040/015</p> <p>Lower die for Rivet application without Back Part (Rivet casing 088): art. 9070/011</p> <p>Vacuum adapter for upper die: art. 9040/023</p> <p><b>Rivet 53 006</b></p> <p>Upper die (M8): art. 9040/067</p> <p>Upper die (M6): art. 9040/066</p> <p>Spare part (plastic insert) for upper die (art. 9040/067 and 9040/066): art. 9040/065</p> <p>Lower die for Rivet application with Back Part 53 007: art. 9070/010</p> <p>Lower die for Rivet application with Back Part 53 009: art. 9070/012</p> <p>Lower die for Rivet application without Back Part (Rivet casing 081, 082 and 086): art. 9040/015</p> <p>Lower die for Rivet application without Back Part (Rivet casing 088): art. 9070/011</p> <p>Vacuum adapter for upper die: art. 9040/023</p> <p><b>Rivet 53 008</b></p> <p>Upper die (M8): art. 9040/083</p> <p>Upper die (M6): art. 9040/085</p> <p>Spare part (plastic insert) for upper die (art. 9040/083 and 9040/085): art. 9040/084</p> <p>Lower die for Rivet application with Back Part 53 009: art. 9070/012</p> <p>Lower die for Rivet application without Back Part (Rivet casing 088): art. 9070/011</p> <p>Vacuum adapter for upper die: art. 9040/023</p>	
Tools for Crystal Pearl Rivets (fly press)	<p>Swarovski:</p> <p><b>Crystal Pearl Rivet 53 400</b></p> <p>Upper die (M8): art. 9040/068</p> <p>Upper die (M6): art. 9040/071</p> <p>Spare part (plastic insert) for upper die (art. 9040/068 and 9040/071): art. 9040/074</p> <p>Lower die for Rivet application with Back Part 53 007: art. 9070/010</p> <p>Lower die for Rivet application with Back Part 53 009: art. 9070/012</p> <p>Lower die for Rivet application without Back Part (Rivet casing 081, 082 and 086): art. 9040/015</p> <p>Vacuum adapter for upper die: art. 9040/023</p>	www.swarovski.com/professional

MACHINES / TOOLS / AIDS	SUPPLIER	CONTACT
(cont. from page 146)	<p><b>Crystal Pearl Rivet 53 401</b></p> <p>Upper die (M8): art. 9040/069</p> <p>Upper die (M6): art. 9040/072</p> <p>Spare part (plastic insert) for upper die (art. 9040/069 and 9040/072): art. 9040/075</p> <p>Lower die for Rivet application with Back Part 53 007: art. 9070/010</p> <p>Lower die for Rivet application with Back Part 53 009: art. 9070/012</p> <p>Lower die for Rivet application without Back Part (Rivet casing 081, 082 and 086): art. 9040/015</p> <p>Vacuum adapter for upper die: art. 9040/023</p> <p><b>Crystal Pearl Rivet 53 402</b></p> <p>Upper die (M8): art. 9040/070</p> <p>Upper die (M6): art. 9040/073</p> <p>Spare part (plastic insert) for upper die (art. 9040/070 and 9040/073): art. 9040/076</p> <p>Lower die for Rivet application with Back Part 53 007: art. 9070/010</p> <p>Lower die for Rivet application with Back Part 53 009: art. 9070/012</p> <p>Lower die for Rivet application without Back Part (Rivet casing 081, 082 and 086): art. 9040/015</p> <p>Vacuum adapter for upper die: art. 9040/023</p>	
Tools for Square Rivets (fly press)	<p>Swarovski:</p> <p><b>Square Rivet 53 500</b></p> <p>Upper die: art. 9040/106</p> <p>Lower die for Rivet application with Back Part 53 007: art. 9070/010</p> <p>Lower die for Rivet application with Back Part 53 009: art. 9070/012</p> <p>Lower die for Rivet application without Back Part (Rivet casing 081, 082 and 086): art. 9040/015</p> <p>Lower die for Rivet application without Back Part (Rivet casing 088): art. 9070/011</p> <p>Vacuum adapter for upper die: art. 9040/105</p> <p><b>Square Rivet 53 501</b></p> <p>Upper die: art. 9040/107</p> <p>Lower die for Rivet application with Back Part 53 007: art. 9070/010</p> <p>Lower die for Rivet application with Back Part 53 009: art. 9070/012</p> <p>Lower die for Rivet application without Back Part (Rivet casing 081, 082 and 086): art. 9040/015</p> <p>Vacuum adapter for upper die: art. 9040/105</p>	<p><a href="http://www.swarovski.com/professional">www.swarovski.com/professional</a></p>

MACHINES / TOOLS / AIDS	SUPPLIER	CONTACT
(cont. from page 147)	<p><b>Square Rivet 53 502</b></p> <p>Upper die: art. 9040/108</p> <p>Lower die for Rivet application with Back Part 53 007: art. 9070/010</p> <p>Lower die for Rivet application with Back Part 53 009: art. 9070/012</p> <p>Lower die for Rivet application without Back Part (Rivet casing 081, 082 and 086): art. 9040/015</p> <p>Vacuum adapter for upper die: art. 9040/105</p>	
Tools for Chessboard Rivets (fly press)	<p>Swarovski:</p> <p><b>Chessboard Rivet 53 600</b></p> <p>Upper die (M8): art. 9040/110</p> <p>Upper die (M6): art. 9040/109</p> <p>Spare part (plastic insert) for upper die (art. 9040/110 and 9040/109): art. 9040/111</p> <p>Lower die for Rivet application with Back Part 53 007: art. 9070/010</p> <p>Lower die for Rivet application with Back Part 53 009: art. 9070/012</p> <p>Vacuum adapter for upper die: art. 9040/105</p>	<a href="http://www.swarovski.com/professional">www.swarovski.com/professional</a>
Tools for Star Rivets (fly press)	<p>Swarovski:</p> <p><b>Star Rivet 53 700</b></p> <p>Upper die: art. 9040/112</p> <p>Spare part (plastic insert) for upper die (art. 9040/112): art. 9040/113</p> <p>Lower die for Rivet application with Back Part 53 007: art. 9070/010</p> <p>Lower die for Rivet application with Back Part 53 009: art. 9070/012</p> <p>Lower die for Rivet application without Back Part (Rivet casing 081, 082 and 086): art. 9040/015</p> <p>Vacuum adapter for upper die: art. 9040/105</p>	<a href="http://www.swarovski.com/professional">www.swarovski.com/professional</a>
Tools for Spike Rivets (fly press)	<p>Swarovski:</p> <p><b>Spike Rivet 53 010</b></p> <p>Upper die: art. 9040/123</p> <p>Spare part (plastic insert) for upper die (art. 9040/123): art. 9040/124</p> <p>Lower die for Rivet application with Back Part 53 007: art. 9070/010</p> <p>Lower die for Rivet application with Back Part 53 009: art. 9070/012</p> <p>Lower die for Rivet application without Back Part (Rivet casing 081, 082 and 086): art. 9040/015</p> <p>Vacuum adapter for upper die: art. 9040/105</p>	<a href="http://www.swarovski.com/professional">www.swarovski.com/professional</a>

MACHINES / TOOLS / AIDS	SUPPLIER	CONTACT
(cont. from page 148)	<p><b>Spike Rivet 53 011</b></p> <p>Upper die: art. 9040/125</p> <p>Spare part (plastic insert) for upper die (art. 9040/125): art. 9040/126</p> <p>Lower die for Rivet application with Back Part 53 007: art. 9070/010</p> <p>Lower die for Rivet application with Back Part 53 009: art. 9070/012</p> <p>Lower die for Rivet application without Back Part (Rivet casing 081, 082 and 086): art. 9040/015</p> <p>Vacuum adapter for upper die: art. 9040/105</p> <p><b>Spike Rivet 53 503</b></p> <p>Upper die: art. 9040/127</p> <p>Spare part (plastic insert) for upper die (art. 9040/127): art. 9040/128</p> <p>Lower die for Rivet application with Back Part 53 007: art. 9070/010</p> <p>Lower die for Rivet application with Back Part 53 009: art. 9070/012</p> <p>Lower die for Rivet application without Back Part (Rivet casing 081, 082 and 086): art. 9040/015</p> <p>Vacuum adapter for upper die: art. 9040/105</p>	
Tools for Rose Pins (fly press)	<p>Swarovski:</p> <p><b>Rose Pin 53 301</b></p> <p>Upper die (M6): art. 9040/090</p> <p>Spare part (plastic insert) for upper die (art. 9040/090): art. 9040/094</p> <p>Lower die: art. 9070/013</p> <p>Centering aid: art. 9070/017</p> <p><b>Rose Pin 53 302</b></p> <p>Upper die (M6): art. 9040/091</p> <p>Spare part (plastic insert) for upper die (art. 9040/091): art. 9040/095</p> <p>Lower die: art. 9070/014</p> <p><b>Rose Pin 53 303</b></p> <p>Upper die (M6): art. 9040/092</p> <p>Spare part (plastic insert) for upper die (art. 9040/092): art. 9040/096</p> <p>Lower die: art. 9070/014</p> <p><b>Rose Pin 53 304</b></p> <p>Upper die (M6): art. 9040/093</p> <p>Spare part (plastic insert) for upper die (art. 9040/093): art. 9040/097</p> <p>Lower die: art. 9070/016</p>	<p><a href="http://www.swarovski.com/professional">www.swarovski.com/professional</a></p>

MACHINES / TOOLS / AIDS	SUPPLIER	CONTACT
Tools for Chessboard Pins (fly press)	<p>Swarovski:</p> <p><b>Chessboard Pin 53 310</b></p> <p>Upper die: art. 9040/114</p> <p>Spare part (plastic insert) for upper die (art. 9040/114): art. 9040/117</p> <p>Lower die: art. 9070/019</p> <p>Vacuum adapter for upper die: art. 9040/105</p> <p><b>Chessboard Pin 53 311</b></p> <p>Upper die: art. 9040/115</p> <p>Spare part (plastic insert) for upper die (art. 9040/115): art. 9040/118</p> <p>Lower die: art. 9070/020</p> <p>Vacuum adapter for upper die: art. 9040/105</p>	<a href="http://www.swarovski.com/professional">www.swarovski.com/professional</a>
Tools for Rhombus Pins (fly press)	<p>Swarovski:</p> <p><b>Rhombus Pin 53 320</b></p> <p>Upper die: art. 9040/116</p> <p>Spare part (plastic insert) for upper die (art. 9040/116): 9040/119</p> <p>Lower die: art. 9070/021</p> <p>Centering aid: art. 9070/022</p> <p>Vacuum adapter for upper die: art. 9040/105</p>	<a href="http://www.swarovski.com/professional">www.swarovski.com/professional</a>
Tools for Crystal Studs (fly press)	<p>Swarovski:</p> <p><b>Crystal Stud 53 730 and 53 731</b></p> <p>Buttonhole punching tool: art. 9040/122</p> <p>Upper die (M6): art. 9040/120</p> <p>Lower die: art. 9040/121</p>	<a href="http://www.swarovski.com/professional">www.swarovski.com/professional</a>
Vacuum pump with silicone hose	Swarovski: art. 9040/022	<a href="http://www.swarovski.com/professional">www.swarovski.com/professional</a>
Hand tool	Jewelrythings, Inc.	<a href="http://www.jewelrythings.com">www.jewelrythings.com</a>
Automatic attaching machine	<p>Jiuzhou Machinery Co., Ltd.</p> <p>Prym Fashion GmbH</p> <p>Seung Min Industrial Co., Ltd.</p> <p>S.P.S. Tecnologia Meccanica Srl</p>	<p><a href="http://www.sinojiuzhou.com">www.sinojiuzhou.com</a></p> <p><a href="http://www.prym-fashion.com">www.prym-fashion.com</a></p> <p><a href="http://www.seungminsm.co.kr">www.seungminsm.co.kr</a></p> <p><a href="http://www.spstecnologiameccanicasrl.it">www.spstecnologiameccanicasrl.it</a></p>

## APPLICATION

Various Swarovski products can be applied using mechanical force, creating a lasting bond with the carrier material.

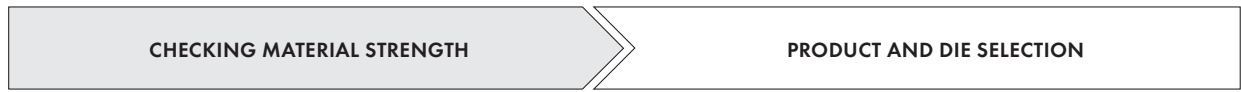

It is very important to carefully check the thickness of the fabric or leather before beginning the application process. With very thick fabrics, a hole can be punched beforehand for the application of Jeans Buttons and Rivets. The fabric should not crinkle or become gathered after application. To check this, carry out tests on fabric or leather scraps before going ahead with the application process. It is also important to make sure that the die sits straight and firmly in the fly press, as this can often cause application problems. It is recommended that you carry out a few test runs to identify the ideal pressure. The offset/pressure can be regulated using an adjustable stop that is fastened to the handle of the fly press. ?!



### Snap Fasteners and Decorative Buttons

To apply Snap Fasteners and Decorative Buttons with a fly press, first fix the required dies into place in the fly press. A Decorative Button is the upper part of a Snap Fastener, which is applied purely for decorative purposes and thus does not require a closure. When applying Snap Fasteners, a second stage is required in order to fix the closure in place.

#### STAGE 1: DECORATIVE BUTTONS/UPPER PART OF SNAP FASTENERS

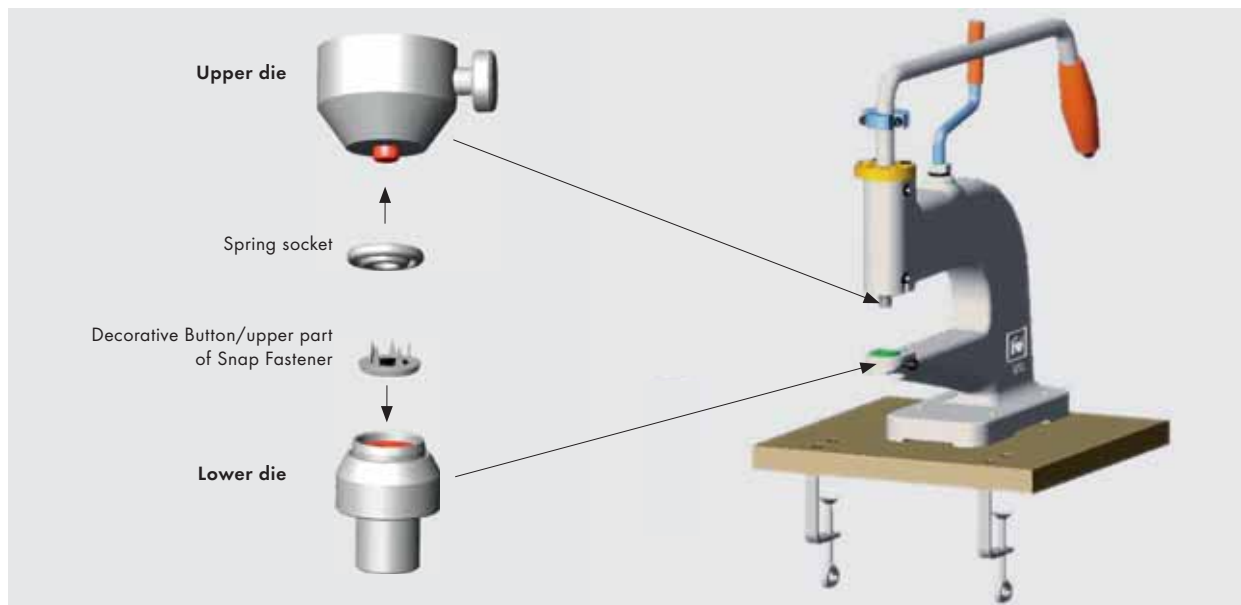



1 Place the Decorative Button/upper part of the Snap Fastener in the lower die, with the claws pointing upwards.



2 Place the spring socket in the upper die.



3 Apply the product to the textile in the previously marked position. Regulate the offset/pressure using the adjustable stop.

**Note:** To make finding the right application position easier, it can be marked prior to the application. Therefore place the textile on an eraser and put the Decorative Button / upper part of the Snap Fastener on top of it (with claws pointing downwards). Press the Button into the textile. The material is marked while the eraser prevents the claws from getting destroyed.

## STAGE 2: SNAP FASTENER CLOSURE

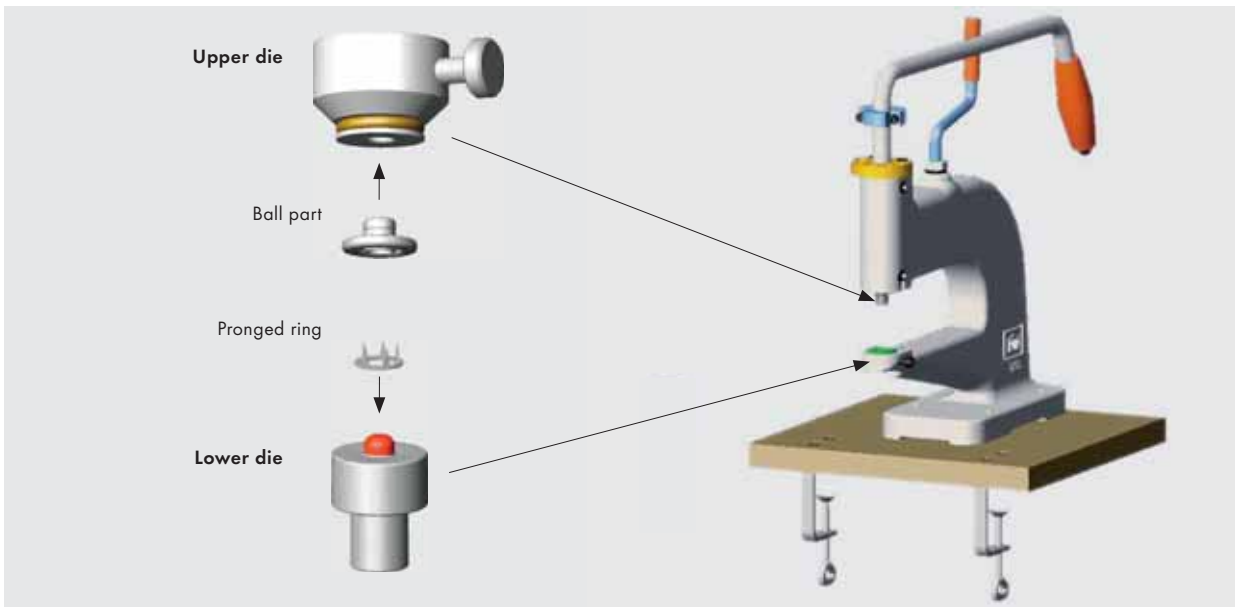

1 Place the pronged ring in the lower die, with the prongs pointing upwards.



2 Place the ball part in the upper die.







3 Apply the product to the textile in the previously marked position, ensuring it is on the right side of the fabric. Regulate the offset/pressure using the adjustable stop.



## Inset Snap Fastener

Inset Snap Fasteners can be easily applied by using a fly press or a pneumatic attaching machine. The Inset Snap Fastener consists of following components:

COMPONENTS			
			
Open metal cap	Backing washer	Socket	Crystal socket

### STAGE 1: PRE-PUNCHING OF THE CARRIER MATERIAL

It is necessary to pre-punch the carrier material before the application of the front and the back part of the Inset Snap Fastener. Material – fabric or multiple layers up to a thickness of 5.00 mm – may be pre-punched all together.



1 Fix the required dies into place in the fly press and start the pre-punching process.



2 Care must be taken that the pre-punching process is in the exact position of the intended application of the Inset Snap Fastener. The front and the back of the fabric can be pre-punched at once.

### STAGE 2: APPLICATION OF THE FRONT PART



1 Insert the required dies into the fly press. First, place the socket, with its shaft facing upwards into the lower die. Please ensure that it sits firmly in the lower die.



2 The backing washer, with the rounded face downwards, is then slid over the socket shaft.



3 The pre-punched material is now laid over the combination of the socket and backing washer. Double check if it is the right side of the fabric. Turn the front side up. The open metal cap, with the rounded face upwards, is slid over the socket shaft and onto the carrier material. Regulate the pressure using the adjustable stop.

### STAGE 3: APPLICATION OF THE BACK PART



1 Change only the lower die. The upper die is used to apply both front and back part. Insert the crystal socket into the lower die with its shaft facing upwards and the crystal pointing down.



2 Slide one backing washer – rounded face downwards – over the socket shaft.



3 The pre-punched material is now placed on top of both the crystal socket and the backing washer. Care must be taken to ensure the application is on the right side of the fabric. Turn the back up. The next step is to place the second backing washer onto the carrier material with the rounded section facing upwards.

## XIRIUS Flat Back Snap Fastener

XIRIUS Flat Back Snap Fasteners can be easily applied using a fly press. The application is divided into two steps as the product consists of two parts (decorative part and closure).

It is important to carefully check and to consider the thickness of the fabric before beginning the application process.

ART.	SIZE	MATERIAL THICKNESS*
1783/300	SS 20	1 - 3 mm

\* Could vary due to character and production of carrier materials.

The material should not contract or crinkle after the application. To avoid this happening, tests are highly recommended on some fabric samples before starting the final application process.

In order to prevent possible injury, the wearing of protective eyewear is recommended when mechanically applying crystal products.

### STAGE 1: APPLICATION OF THE DECORATIVE (UPPER) PART



1 Place the vacuum adapter and the tools in the fly press. Make sure that they are fixed and connect the vacuum adapter to vacuum pump.



2 Place the decorative part in the upper die and the spring socket in the lower die. The vacuum will keep the decorative part in upper position during application.



3 Apply the product on the carrier material. Adjust the offset/pressure using the adjustable stop.

### STAGE 2: APPLICATION OF THE CLOSURE (LOWER) PART



1 Replace the upper and lower die in order to apply the Snap Fastener closure.



2 Place the ball part in the upper die (will be kept in position by vacuum) and the counterpart in the lower die.



3 Apply the product on the carrier material. Adjust the offset/pressure using the adjustable stop. Check the functionality of the Snap Fastener after the application.

## Jeans Buttons

To apply Jeans Buttons, first fix the required dies into place in the fly press. When applying Jeans Buttons 1790/104, 1790/140, 1791/120, 1792/100, 1796/140 and 1797/140 the corresponding plastic insert has to be changed.

### CHANGING THE PLASTIC INSERT



1 To change the insert according to the Swarovski products used, you will need the changing pin and the new plastic insert.



2 Use the changing pin to slowly slide the plastic insert out of the attaching die from above, through the hole.

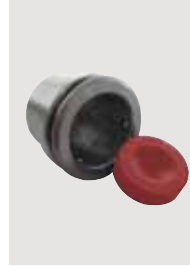

3 Press the new plastic insert into the attaching die right up to the top.

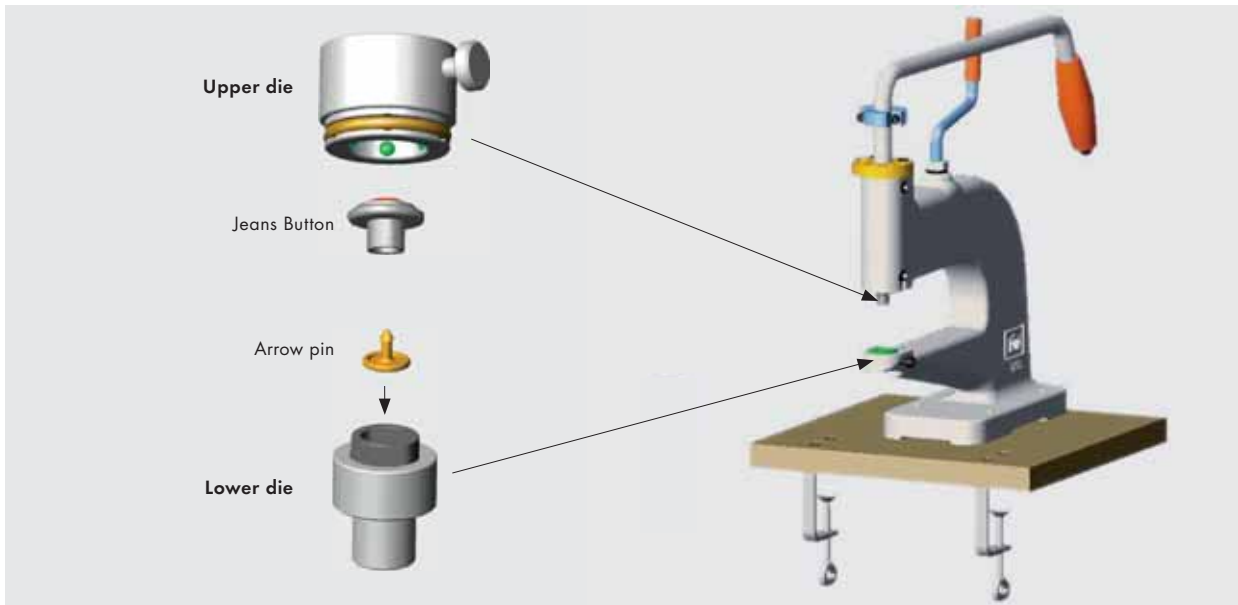
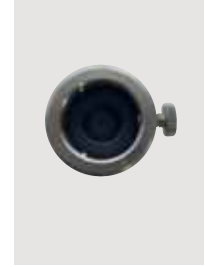

1 Place the top part of the Jeans Button in the upper die.



2 Place the arrow pin in the lower die.



3 Carry out the application in the desired position. Regulate the offset/pressure using the adjustable stop.

## Rivets

For the application of Rivets, use a fly press or a semi-automatic attaching machine: The following instructions focus on the application with the fly press. As a first step, attach the appropriate die to the fly press.

Rivets can be applied on various materials with or without Back Parts. Rivet 53 002 is specially designed for application without a Back Part. For applications on leather, Stainless Steel Rivets (color code 088) and Back Parts are recommended.

Please note the material thickness when selecting Rivets. The dies should be selected accordingly.

	ART.	SIZE	MATERIAL THICKNESS*	POSSIBLE BACK PARTS
<b>RIVETS</b>	<b>53 008</b>	PP 24	1.5 - 2.0 mm	53 009
	<b>53 000</b>	SS 18	2.0 - 2.5 mm	53 007 and 53 009
	<b>53 001</b>	SS 29	2.0 - 2.5 mm	53 007 and 53 009
	<b>53 005</b>	SS 34	2.0 - 2.5 mm	53 007 and 53 009
	<b>53 006</b>	SS 39	2.2 - 2.7 mm	53 007 and 53 009
<b>RIVET FLAT SHAFT<sup>1</sup></b>	<b>53 003</b>	SS 29	2.0 - 3.5 mm	
<b>CRYSTAL PEARL RIVETS</b>	<b>53 400</b>	6 mm	2.0 - 2.5 mm	53 007 and 53 009
	<b>53 401</b>	8 mm	2.0 - 2.5 mm	53 007 and 53 009
	<b>53 402</b>	10 mm	2.2 - 2.7 mm	53 007 and 53 009
<b>SQUARE RIVETS</b>	<b>53 500</b>	4 mm	2.0 - 2.5 mm	53 007 and 53 009
	<b>53 501</b>	6 mm	2.0 - 2.5 mm	53 007 and 53 009
	<b>53 502</b>	8 mm	2.2 - 2.7 mm	53 007 and 53 009
<b>CHESSBOARD RIVETS</b>	<b>53 600</b>	6 mm	2.0 - 2.5 mm	53 007 and 53 009
<b>STAR RIVETS</b>	<b>53 700</b>	10 mm	1.5 - 3.0 mm	53 007 and 53 009
<b>SPIKE RIVETS</b>	<b>53 010</b>	SS 29	2.0 - 3.0 mm	53 007 and 53 009
	<b>53 011</b>	SS 39	2.0 - 3.0 mm	53 007 and 53 009
	<b>53 503</b>	8 mm	2.0 - 3.0 mm	53 007 and 53 009

\* This can vary according to the roughness and production of the carrier material.

In many cases it is possible to select between both versions of the Back Part. For applications on **thinner fabrics**, it is better to use the **larger** Back Part (art. 53 007). Its size means this Back Part can better hold the split Rivet shaft, avoiding any damage to the crystal.

For **multi-layered or thicker** materials, the **smaller** Back Part (art. 53 009) can be used. To create a lasting bond, this requires less space for the split Rivet shaft. If the carrier material proves too thick, or is made up of several layers, it is recommended to punch a hole before application.

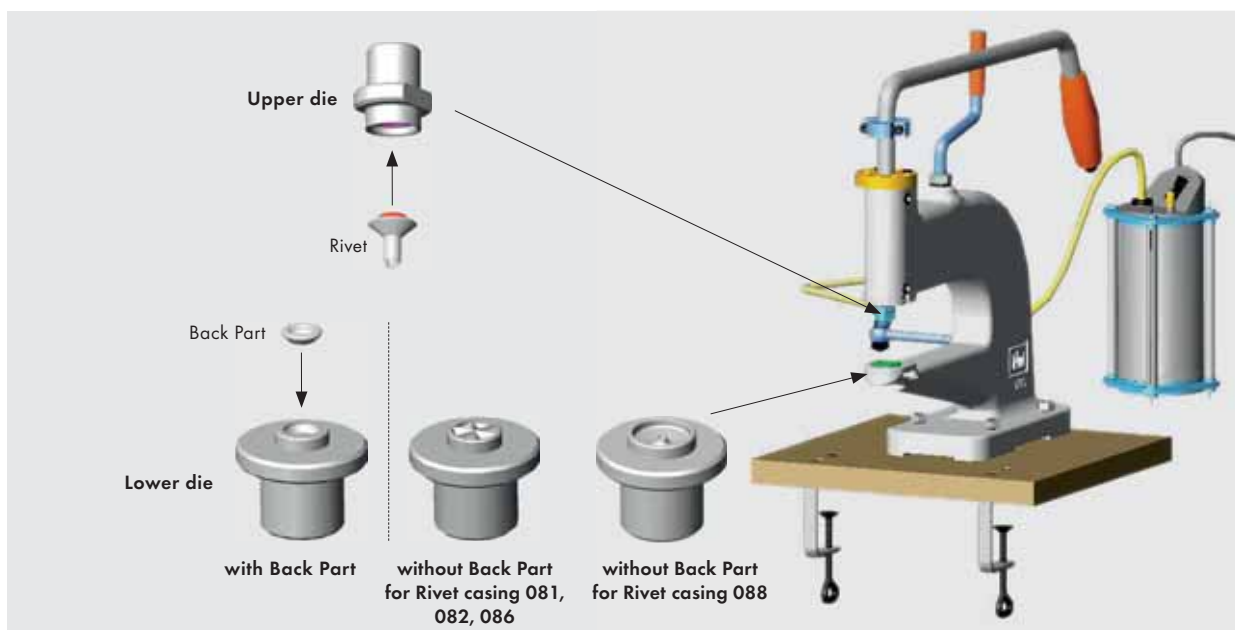

<sup>1</sup> 53 003 is designed for ring rolling application and is self-backing. The rivet can be proceed on automatic and semi-automatic machines as well as with a fly press and therefore use lower die 9070/010 without any back part (53 007).

### Rose Pins, Chessboard Pins and Rhombus Pins

Pins can be easily applied using a fly press, a semi- or fully-automated attaching machine or a hand tool. The application with the fly press and the semi-automatic attaching machine will be explained step by step. Please note the material thickness when selecting Pins.

	ART.	SIZE	MATERIAL THICKNESS*
<b>ROSE PINS</b>	<b>53 301</b>	SS 10	1 - 2 mm
	<b>53 302</b>	SS 16	1 - 2 mm
	<b>53 303</b>	SS 20	1 - 2 mm
	<b>53 304</b>	SS 34	1 - 2 mm
<b>CHESSBOARD PINS</b>	<b>53 310</b>	6 mm	1 - 2 mm
	<b>53 311</b>	10 mm	1 - 2 mm
<b>RHOMBUS PINS</b>	<b>53 320</b>	10 x 6 mm	1 - 2 mm

\* This can vary according to the roughness and production of the carrier material.

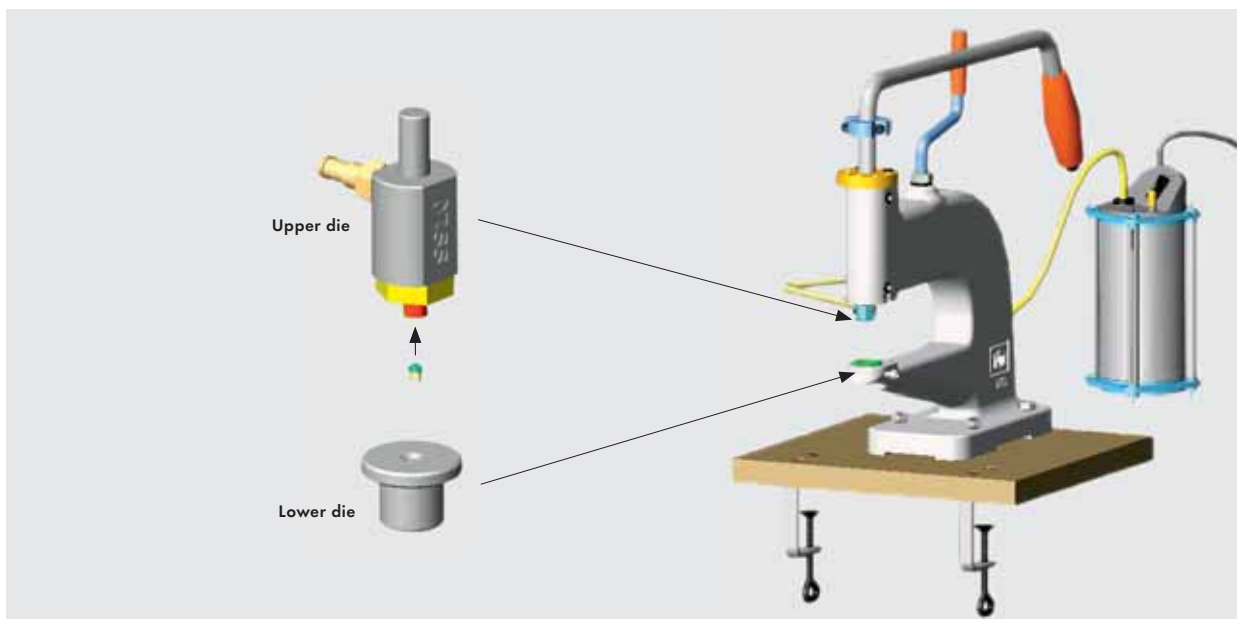

To apply Pins, attach the appropriate die to the fly press.



1 Place the Pin in the upper die.



2 Position the carrier material and apply. Regulate the offset/pressure using the adjustable stop.

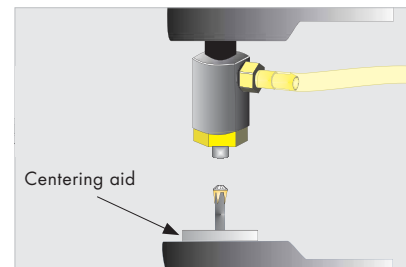

To facilitate the positioning of the small Rose Pin (art. 53 301, SS 10) in the upper die, the centering aid can be used. The tool must be removed before applying the Rose Pin.

**Note:** Do not apply Pins on areas of the carrier material that are under high mechanical stress (e.g. shoe industry). After application, ensure the Pins are not heated up to more than 80 °C (176 °F).

## APPLICATION WITH A SEMI-AUTOMATIC ATTACHING MACHINE

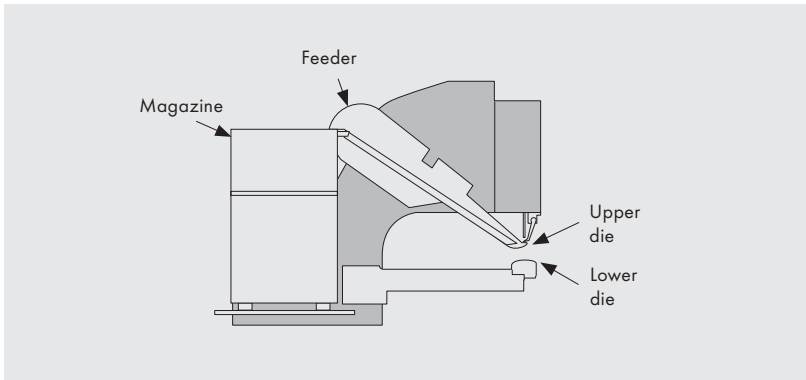

To apply Rose Pins and Chessboard Pins, the semi-automatic attaching machine must be adjusted to the Pin size and carrier material (dies, feed and magazine). Please follow the machine manufacturer's instructions (S.P.S. Tecnologia Meccanica).



1 Set up the machine.



2 Add the Rose Pins.



3 Position the carrier material and apply.

**Note:** When applying Rose Pin motifs, it is helpful to have a corresponding template or marking on the carrier material to ensure the correct positioning.

## Crystal Studs

Crystal Studs can be easily applied to various materials by using a fly press. Please consider the material thickness.

ART.	LENGTH OF SHANK	MATERIAL THICKNESS*
53 730	8 mm	0.5 – 4.0 mm
53 731	6 mm	0.5 – 2.5 mm

\* This can vary according to the roughness and production of the carrier material.

It is important to carefully check the thickness of the fabric before beginning the application process. To avoid contraction or crinkling of the material after the application, tests are highly recommended on fabric samples before going ahead with the actual application process.



1 Pre-punch the carrier material on the designated position for the Crystal Stud.



2 Place the tools in the fly press. Make sure that they are sitting straight and firmly.



3 Connect the vacuum pump and turn it on.



4 Place the lower part of the Crystal Stud in the lower die.



5 Place the lower part in the upper die (crystal pointing upwards).



6 Put the carrier material with the pre-punched hole over the lower part.



7 Apply the Crystal Stud by closing the handle.



8 The Crystal Stud is now applied.



9 Create the buttonhole with a buttonhole punching tool (art. 9040/122).



10 The latch can be closed now.

## USEFUL INFORMATION

### Optimum product/die alignment

In general, when carrying out mechanical applications it is important to ensure the proper alignment of products in the dies, so as to avoid any problems.

?!  
!

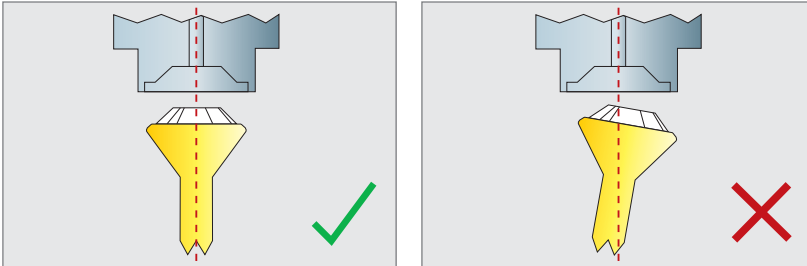

### Minimum gaps

Please note that during application, the product is entirely surrounded by the upper die. To prevent neighboring products from being damaged, check the minimum space required by the die when calculating the gap between each item.

?!  
!

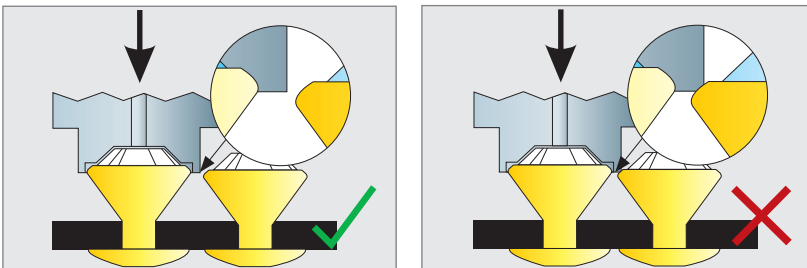

### Die maintenance

Please check the dies used before and during production, and change them when they become worn. For machines with vacuum connections, blockages in the upper die can be released using a needle.



## QUICK ASSISTANCE

The following table outlines common problems with mechanical applications and their causes, and offers advice on how to avoid them. Further details and descriptions can be found in the section marked with a **?!**

PROBLEM	CAUSE
The product is not ideally affixed onto the carrier material.	1, 2, 3, 4, 5
The fabric ripples or crinkles.	2, 3, 4, 5
The dies cannot be inserted in the fly press.	3, 6, 7, 8
It is not possible to unscrew the dies.	6, 8, 9
The crystals break.	2, 3, 4, 5, 10
The crystals do not hold in the upper die.	12, 13

CAUSE	RECOMMENDATION
1 The pressure may be too low.	Apply the product again using increased pressure; adjust the stop.
2 The carrier material is too thick or consists of too many layers.	With Rivets, select the smaller Back Part. With Rivets and Jeans Buttons a hole can be pre-punched.
3 The dies/spare parts for the upper die are defective or have been wrongly inserted.	Check the dies and if necessary, replace or repair them.
4 The product has been applied using the wrong dies.	Check to make sure that the right dies are being used for the product.
5 The dies have not been inserted correctly.	Make sure that the products are placed exactly in the right position on the dies. By turning the fly press handle slowly, it is possible to see if the upper and lower parts of the tool meet exactly.
6 The fly press and dies do not fit together.	Make sure that the fly press and the upper die have the same thread size (M6 or M8).
7 The upper die cannot be fitted.	Check the fastening screw on the upper die; it may have been screwed too tightly.
8 The die/spare part may be damaged.	Check the dies; if they are faulty use a new die or spare part.
9 The screw on the upper die has broken off.	Carefully try to loosen the screw using pliers. Oil from time to time; it may be necessary to center-drill the die.
10 The pressure may be too high.	Apply the product again using slightly less pressure; adjust the stop.
11 The die damages the crystal.	Check the dies and if necessary replace the upper die or the spare parts.
12 The vacuum hose is blocked or damaged.	Check and if necessary change the vacuum hose.
13 The vacuum hole in the upper die (Rivet) is blocked.	Clean the vacuum hole and if necessary change the spare part.



## **CARE INSTRUCTIONS**

To ensure the highest quality and longest-lasting applications of Swarovski products, proper care is essential. The Swarovski Hotfix adhesive is characterized by its wash resistance and easy-care properties.

## TEXTILE CARE INSTRUCTIONS

								
<b>General Recommendations</b>		Turn inside out, choose a gentle wash cycle and use mild laundry detergent.			Turn inside out and use mild laundry detergent.	Do not wash!	Chlorine bleach may be used.	Do not use chlorine bleach!
		To protect the crystals as much as possible, the use of a soft wash bag is recommended.						
Round Stones		✓						✓
Fancy Stones		✓						✓
Beads	Beads	✓						✓
	Crystal Mesh Balls				✓			✓
BeCharmed & Pavé			✓					✓
Crystal Pearls					✓			✓
Pendants						✓		✓
Flat Backs No Hotfix <sup>1</sup>		✓						✓
Flat Backs Hotfix	XILION Rose & XIRIUS Rose <sup>1</sup>	✓						✓
	Framed Flat Backs	✓						✓
	Creation Stones	✓						✓
	Creation Stones Plus <sup>2</sup>				✓			✓
	Cabochons				✓			✓
Sew-on Articles		✓						✓
Self-adhesive Elements						✓		✓
Transfers	XILION Transfers & XIRIUS Transfers	✓						✓
	Creation, Diamond	✓						✓
	Metallic & Mezzo Transfers		✓					✓
	Creation Transfers Plus <sup>2</sup>				✓			✓
	Pearl Transfers				✓			✓
Synthetics Hotfix	Crystal Fabric		✓					✓
	Crystal Rocks & Crystal Fine Rocks		✓					✓
	Graphic Fabric & Graphic (Fine) Rocks				✓			✓
	Crystal Medley		✓					✓
	Crystalltex <sup>3</sup>		✓					✓
Plastic Trimmings	Basic Bandings	✓						✓
	Fishnet Bandings	✓						✓
	Decorative Bandings		✓					✓
	Plastic Components		✓					✓
Buttons, Fasteners & Zippers	Crystal Buttons	✓						✓
	Buttons with Plastic Shank		✓					✓
	Snap Fasteners & Decorative Buttons		✓					✓
	Jeans Buttons		✓					✓
	Buttons with Metal Shank		✓					✓
	Zippers			✓				✓
Metal Trimmings	Chaton & Flat Back Bandings & Spike Bandings				✓			✓
	Rivets, Square Rivets, Chessboard Rivets & Star Rivets		✓					✓
	Crystal Pearl Rivets				✓			✓
	Spike Rivets				✓			✓
	Roses & Chaton Montées		✓					✓
	Rose Pins, Chessboard Pins & Rhombus Pins		✓					✓
	Crystal Studs				✓			✓
Crystal Mesh					✓			✓
Cupchains & Findings						✓		✓

1 XIRIUS size SS 40 and SS 48: only wash with a hand wash program.

2 Creation Stones Plus have a stone size of 8 - 10 mm.

3 It is recommended to wash Crystalltex Cabochon with a hand wash program.

## TEXTILE CARE INSTRUCTIONS

					
	Turn inside out and dry at reduced temperature.	Do not tumble dry!	Iron inside out using a silk/polyester/viscose setting. Ironing the textile inside out and using a pressing cloth is recommended.	Iron inside out using a wool setting.	Do not iron! Do not iron directly over the crystals.
Round Stones		✓			✓
Fancy Stones		✓			✓
Beads	Beads	✓			✓
	Crystal Mesh Balls		✓		✓
BeCharmed & Pavé		✓			✓
Crystal Pearls		✓			✓
Pendants		✓			✓
Flat Backs No Hotfix <sup>1</sup>		✓			✓
Flat Backs Hotfix	XILION Rose & XIRIUS Rose <sup>1</sup>	✓		✓	
	Framed Flat Backs			✓	
	Creation Stones	✓		✓	
	Creation Stones Plus <sup>2</sup>		✓		✓
	Cabochons	✓		✓	
Sew-on Articles		✓			✓
Self-adhesive Elements		✓			✓
Transfers	XILION Transfers & XIRIUS Transfers	✓		✓	
	Creation, Diamond	✓		✓	
	Metallic & Mezzo Transfers		✓	✓	
	Creation Transfers Plus <sup>2</sup>		✓		✓
	Pearl Transfers	✓		✓	
Synthetics Hotfix	Crystal Fabric		✓	✓	
	Crystal Rocks & Crystal Fine Rocks		✓	✓	
	Graphic Fabric & Graphic (Fine) Rocks		✓	✓	
	Crystal Medley		✓	✓	
	Crystaltex <sup>3</sup>		✓	✓	
Plastic Trimmings	Basic Bandings	✓			✓
	Fishnet Bandings		✓		✓
	Decorative Bandings		✓		✓
	Plastic Components		✓		✓
Buttons, Fasteners & Zippers	Crystal Buttons		✓		✓
	Buttons with Plastic Shank		✓		✓
	Snap Fasteners & Decorative Buttons		✓		✓
	Jeans Buttons		✓		✓
	Buttons with Metal Shank		✓		✓
Zippers		✓			✓
Metal Trimmings	Chaton & Flat Back Bandings & Spike Bandings		✓		✓
	Rivets, Square Rivets, Chessboard Rivets & Star Rivets		✓		✓
	Crystal Pearl Rivets		✓		✓
	Spike Rivets		✓		✓
	Roses & Chaton Montées		✓		✓
	Rose Pins, Chessboard Pins & Rhombus Pins		✓		✓
Crystal Studs					✓
Crystal Mesh		✓			✓
Cupchains & Findings		✓			✓

## TEXTILE CARE INSTRUCTIONS

					
		The textile can be gently dry-cleaned using perchlorethylene. Turn inside out.	The textile can be gently dry-cleaned using hydrocarbon. Turn inside out.	The textile will withstand gentle professional wet cleaning. Turn inside out.	The textile may not be dry-cleaned.
		To protect the crystals as much as possible, the use of a soft wash bag is recommended.			
Round Stones			✓	✓	
Fancy Stones			✓	✓	
Beads	Beads	✓	✓	✓	
	Crystal Mesh Balls		✓	✓	
BeCharmed & Pavé			✓	✓	
Crystal Pearls			✓	✓	
Pendants					✓
Flat Backs No Hotfix <sup>1</sup>			✓	✓	
Flat Backs Hotfix	XILION Rose & XIRIUS Rose <sup>1</sup>	✓	✓	✓	
	Framed Flat Backs	✓	✓	✓	
	Creation Stones	✓	✓	✓	
	Creation Stones Plus <sup>2</sup>	✓	✓	✓	
	Cabochons	✓	✓	✓	
Sew-on Articles		✓	✓	✓	
Self-adhesive Elements					✓
Transfers	XILION Transfers & XIRIUS Transfers	✓	✓	✓	
	Creation, Diamond	✓	✓	✓	
	Metallic & Mezzo Transfers		✓	✓	
	Creation Transfers Plus <sup>2</sup>	✓	✓	✓	
	Pearl Transfers	✓	✓	✓	
Synthetics Hotfix	Crystal Fabric		✓	✓	
	Crystal Rocks & Crystal Fine Rocks		✓	✓	
	Graphic Fabric & Graphic (Fine) Rocks		✓	✓	
	Crystal Medley		✓	✓	
	Crystaltex <sup>3</sup>		✓	✓	
Plastic Trimmings	Basic Bandings	✓	✓	✓	
	Fishnet Bandings	✓	✓	✓	
	Decorative Bandings	✓	✓	✓	
	Plastic Components	✓	✓	✓	
Buttons, Fasteners & Zippers	Crystal Buttons	✓	✓	✓	
	Buttons with Plastic Shank	✓	✓	✓	
	Snap Fasteners & Decorative Buttons	✓	✓	✓	
	Jeans Buttons		✓	✓	
	Buttons with Metal Shank		✓	✓	
	Zippers		✓	✓	
Metal Trimmings	Chaton & Flat Back Bandings & Spike Bandings		✓	✓	
	Rivets, Square Rivets, Chessboard Rivets & Star Rivets	✓	✓	✓	
	Crystal Pearl Rivets		✓	✓	
	Spike Rivets	✓	✓	✓	
	Roses & Chaton Montées	✓	✓	✓	
	Rose Pins, Chessboard Pins & Rhombus Pins	✓	✓	✓	
	Crystal Studs		✓	✓	
Crystal Mesh			✓	✓	
Cupchains & Findings					✓

---

## GENERAL CARE INSTRUCTIONS

A light layer of dust is most easily removed with a clean, dry and antistatic cloth. To avoid unsightly fingerprints on the crystal, wear white cotton gloves during the cleaning process. For heavier dirt, lukewarm water with a little dishwashing detergent will suffice. Ideally you should use a damp and clean microfiber or thin, lint-free cotton cloth. Gently wipe each individual crystal and dry with a clean cloth. Again, wearing white cotton gloves is recommended.

When cleaning with moisture, make sure to use cleaning agents that do not damage the surrounding material. By correctly cleaning your Swarovski crystals, you will restore their full reflectivity.



Cloth

---

## LAWS, REGULATIONS, NORMS & STANDARDS

The composition of loose and forward-integrated crystals in the Advanced Crystal standard is compliant with regulatory industry norms and laws regarding the restriction or prohibition of certain

substances for finished products in the most relevant segments of our customers' business.

---

## WARNING NOTICES

### General Warning



Loose crystals may present a small parts hazard to young children, particularly children under three years old. Depending on the size of the crystal and any attached material (such as glue, fabric, etc.), children may choke on, inhale, swallow, or insert the crystal into their noses. Magnetic products with crystal applications pose a particular risk of serious intestinal injury if ingested. The application techniques as stated in the Application Manual do not guarantee that crystals will not come loose. For each application, the manufacturer must determine whether the product meets the relevant requirements related to small parts hazards and assess any risk it may pose to small children. Failure to follow Swarovski's care instructions may result in damage to the crystal, which could pose a risk of laceration or other harm.

### Warning for Crystal Tattoos

Crystal Tattoos may be applied on healthy skin only. Do not adhere to eyes or on mucous membranes. Crystal Tattoos are not recommended for young children. Loose crystals may present a small parts hazard to young children, particularly children under three years old. If a crystal comes loose, depending on the size of the crystal, children may choke on, inhale, swallow, or insert the crystal into their noses.

### Warning for Magnetic Products

Loose crystals may present a small parts hazard to young children, particularly children under three years old. Magnetic products with crystal applications pose a particular risk of serious intestinal injuries if ingested. For each application of magnetic crystal products, the manufacturer must determine whether the product meets relevant requirements related to small parts hazards and assess any risk it may pose to small children.

### Warning for Tableware

The application of loose crystals to tableware presents a potential risk of aspiration, choking, swallowing, or tooth damage should crystals become loose. To reduce this risk, crystals should never be applied to any surface of tableware likely to come in contact with food or the mouth, and crystals should never be placed on any tableware intended for use by children. Tableware with

crystals intended for decorative use only should be marked as such. To avoid dishwasher damage, tableware decorated with crystals should be washed by hand. The application techniques or suggestions in this manual do not guarantee that crystals will not come loose. For each application, the manufacturer must determine whether the product meets relevant requirements related to small parts hazards or use in food contact items and assess any risk it may pose to users.

The use of crystals (which may contain restricted substances deemed hazardous under local laws) and adhesives on tableware is subject to legal restrictions in specific countries. The customer is fully responsible for complying with these country-specific provisions and shall defend, indemnify, and hold Swarovski harmless from any and all third-party claims based on product liability or otherwise relating to uses of Swarovski products, and waives all its own claims against Swarovski.

### Unsuitable Applications

Crystals from Swarovski are intended for use in the fields of fashion, jewelry, accessories, textile products, and for interior décor. Due to their physical properties, crystals from Swarovski are unsuitable for other uses (e.g. gluing onto teeth, using on or near mucous membranes, and other unsafe uses). The customer shall defend, indemnify, and hold Swarovski harmless from any and all third-party claims based on product liability or otherwise relating to uses of Swarovski products purchased by the customer, and waives all its own claims.

### Responsibility of User

Any oral, written, or test-based advice that Swarovski provides regarding techniques for the application of its products are recommendations based on Swarovski's current knowledge and the information provided by its suppliers. Such advice does not discharge the customer from carrying out its own tests of techniques it proposes to use and their suitability for the intended application. The application, use, and processing of these techniques and products are solely the user's responsibility.



---

## CARE INSTRUCTIONS

Not following Swarovski care instructions can damage the product and thus lead to damage of textiles or other damage.

Please note that with all standard washing processes (whether carried out by a household washing machine or via dry cleaning) the rotation of the drum places significant mechanical forces on the textiles. The most important factor in ensuring a secure wash is correctly applying the product, without compromising its adhesion. The larger the product employed, and the more products are applied next to each other, the greater the risk of damage. Swarovski products are made out of crystal or contain crystal and must thus be handled with suitable care.

In general, it is recommended that a soft wash bag is used and that the washer drum is filled to protect against damage. To maintain the quality of crystals from Swarovski, the following is also important: before washing, turn items of clothing inside out, select a gentle wash cycle, and use a mild detergent. According to DIN EN ISO 3758, our care instructions list all product groups, meaning each product used by customers must be assessed separately with regard to its washability and suitability for its purpose/the end product. The recommendations given by Swarovski reflect our current level of knowledge. Swarovski uses these recommendations to decide on the suitability of the product for textile applications. Customers are solely responsible for defining the recommended cleaning process for the end product, and must consider the care advice of Swarovski and any other manufacturers in doing so. The type of shape, cut, surface effect, and size, as well as the weight of the application and the quantity of crystals used has a significant impact on the cleaning process to be followed.

To avoid all risks, customers/textile cleaning companies should remove any large crystal stones, buttons, etc., that have been stitched on before cleaning, and stitch them back on again afterwards.

Content is subject to change without notice.

Errors and misprints excepted.

Please note, the actual products may deviate from the pictures in color and effect.

D. Swarovski Distribution GmbH, Swarovskistrasse 30, 6112 Wattens, Austria

© 2016 D. Swarovski Distribution GmbH. All rights reserved. Partial or total publication, transmission, copy or other duplication of texts, graphics, pictures etc. which are to be found in this publication is forbidden without special consent by D. Swarovski Distribution GmbH.

Swarovski® is a registered trademark of Swarovski AG.

Please visit our website for contact information: [SWAROVSKI.COM/PROFESSIONAL](http://SWAROVSKI.COM/PROFESSIONAL)